

SG-10C

USER'S MANUAL

NOT INTENDED FOR SALE

**Federal Communications Commission
Radio Frequency Interference
Statement**

This equipment generates and uses radio frequency energy and if not installed and used properly, that is, in strict accordance with the manufacturer's instructions, may cause interference to radio and television reception. It has been type tested and found to comply with the limits for a Class B computing device in accordance with the specifications in Subpart J of Part 15 of FCC Rules, which are designed to provide reasonable protection against such interference in a residential installation. However, there is no guarantee that interference will not occur in a particular installation. If this equipment does cause interference to radio or television reception, which can be determined by turning the equipment off and on, the user is encouraged to try to correct the interference by one or more of the following measures:

- Reorient the receiving antenna
- Relocate the computer with respect to the receiver
- Move the computer away from the receiver
- Plug the computer into a different outlet so that computer and receiver are on different branch circuits.

If necessary, the user should consult the dealer or an experienced radio/television technician for additional suggestions. The user may find the following booklet, prepared by the Federal Communications Commission helpful: "How to Identify and Resolve Radio-TV Interference Problems." This booklet is available from the U.S. Government Printing Office, Washington, D.C., 20402, Stock No. 004-000-00345-4.

For compliance with Federal Noise Interference Standard, this equipment requires a shielded cable.

A note about the programs in this manual:

This manual contains several programs that help to demonstrate the versatility of this printer. Star Micronics Co., Ltd. has made every effort to insure that the programs are functional and accurate. However, Star Micronics Co., Ltd. cannot guarantee their accuracy or suitability to any particular application.

Trademark Acknowledgement

SG-10C: Star Micronics Co., Ltd.

Commodore C-64: Commodore Business Machines, Inc.

©Copyright 1985 Star Micronics Co., Ltd.

A Special Message to the New Owner

Congratulations on your selecting the printer of choice for both the sophisticated as well as the first-time user/owner — the new *SG-10C*! Your new printer offers full compatibility with any Commodore on the market. It combines the speed and efficiency of a proven winner with the character sets and printer codes used by the Commodore!

To complement the printer, we've included this manual. All the information you need to be up and running with your new printer is right here!

You'll find using this manual easy and pleasant. We've gone to great lengths to make it so, as it's master-minded by solid experts in the art of computer science, and written by professionals experienced in presenting technical subjects accurately — and in Plain English!

As an example, look over the Table of Contents and you'll see what we mean. Whether you're a greenhorn or a technical wizard, everything you need to know in order to utilize this printer's wealth of features can be found there. We suggest that each new owner/user take time to at least scan Chapter 2 and 3 — "Getting to Know Your Printer" and "Getting Started With Your Printer" — as well as Chapter 1, "Setting Up Your Printer", to become familiar with your printer and how it works.

For you who wish to design your own characters, do your own plotting, your own infinite variety of dot graphic patterns, you'll have a ball! For you, Chapters 5 through 10 are a must, and of course everybody should look at Chapter 11, which tells how to maintain your printer for a long and carefree life.

In this manual there are plenty of example programs to demonstrate and show off all of this printer's features. All the example programs are written in Commodore BASIC for the Commodore C-64.

So, gentle reader, with this manual we hand you the key to the wonderful world of this printer. May you enjoy years of handsome, fast, and carefree printing!

Congratulations on your selecting the printer of choice for the SG-10C!

There is an additional feature as shown below. So please use this new feature as well as the other features described in the Users Manual.

■ International Character Set

This printer is a multi-lingual printer for it can speak eight languages! This printer changes languages by changing 14 characters (5 characters in Graphic mode characters and 9 characters in Business mode characters) that are different for the different languages. These sets of characters are called *international character sets*. The control codes to select the international character sets are shown in Table below.

Table 1
International character set commands and settings of DIP switches

Country	Control code	Settings of DIP switches		
		2-2	2-3	2-4
Commodore Standard	<ESC>"7"CHR\$(0)	ON	ON	ON
U.S.A.	<ESC>"7"CHR\$(1)	OFF	ON	ON
Germany	<ESC>"7"CHR\$(2)	ON	OFF	ON
Denmark	<ESC>"7"CHR\$(3)	OFF	OFF	ON
France	<ESC>"7"CHR\$(4)	ON	ON	OFF
Sweden	<ESC>"7"CHR\$(5)	OFF	ON	OFF
Italy	<ESC>"7"CHR\$(6)	ON	OFF	OFF
Spain	<ESC>"7"CHR\$(7)	OFF	OFF	OFF

In addition, you can select the default international character set by the DIP switches as shown above. The characters that change are shown beneath their ASCII code in the Table below.

Table 2
International character sets
(Graphic mode characters)

Country	35	64	91	92	93
Commodore Standard	#	@	[£]
U.S.A.	#	@	[\]
Germany	#	§	Ä	Ö	Ü
Denmark	#	@	Æ	Ø	Å
France	£	à	°	ç	§
Sweden	#	É	Ä	Ö	Å
Italy	#	§	°	ç	é
Spain	#	@	ı	Ñ	ı

(Business mode characters)

Country	35	64	91	92	93	123	124	125	126
Commodore Standard	#	@	[£]	+	§	ı	⌘
U.S.A.	#	@	{		}	[\]	~
Germany	#	§	ä	ö	ü	Ä	Ö	Ü	ß
Denmark	#	@	æ	ø	å	Æ	Ø	Å	~
France	£	à	é	ù	è	°	ç	§	-
Sweden	#	É	ä	ö	å	Ä	Ö	Å	ü
Italy	#	§	à	ò	è	°	ç	é	ı
Spain	#	@	˘	ñ	ı	ı	Ñ	ı	~

Table of Contents

Chapter 1	Setting Up Your Printer	1
	Where shall we put it?	
	What have we here?	
	Removing the printer cover	
	Removing packing and shipping screws	
	Installing the platen knob	
	Removing the tractor unit	
	Attaching the paper separator and paper guide	
	Installing the ink ribbon	
Chapter 2	Getting to Know Your Printer	9
	Components and Controls	
	Paper Selection and Loading	
	Loading single sheets	
	Loading sprocket-feed paper	
	Adjusting the Gap	
	Self-Test	
Chapter 3	Getting Started With Your Printer	21
	First, some terminology	
	Using this book without learning BASIC	
Chapter 4	Controlling Printer With BASIC	25
	Some basics about BASIC	
	The OPEN command	
	The CMD command	
	The PRINT# command	
	Establishing communications	
	The CHR\$ function	
	Control codes	
Chapter 5	Printing Text With Printer	29
	Some special kinds of text	
	Near Letter Quality characters	
	Italic characters	
	Emphasized printing	
	Changing the print pitch	
	Printing with control codes	
	Expanded print	
	Reverse field print	

Chapter 6	Line Spacing and Forms Control	33
	Starting new lines	
	Changing line spacing	
	Forms controls	
	Form feed	
	Changing the page length	
	Skip over perforation	
Chapter 7	Formatting Your Output	41
	Using one-time tab	
	Formatting a table	
	The formatting characters	
	Numeric data	
	String data	
	Skip	
	Literals in format strings	
	Printing data according to a previously defined format	
Chapter 8	Special Features of The Printer	47
	Now hear this	
	Initializing the printer	
	Graphic mode and business mode	
	Error message printing	
	Quotation marks	
Chapter 9	Creating Your Own Character	53
	Dot matrix printing	
	The print matrix	
	Defining your own character	
	Rule 1: Download characters are eight dots high	
	Rule 2: Dots cannot overlap	
	Add up each column of dots	
	Download character definition command	
	Printing download character	
Chapter 10	Printing With Dot Graphics	63
	Comparing dot graphics with download characters	
	Using the dot graphics command	
	Specifying the graphics data	
	Combining text and graphics	
	Printing a design or logo	
	Creating bar charts	
Chapter 11	Basic Maintenance	69
	Cleaning Your Printer	
	Replacing a Fuse	
	Replacing the Print Head	

Appendix A	DIP Switch Setting	73
	Switch functions	
Appendix B	ASCII Codes And Conversion Chart	77
Appendix C	Character Style Chart	85
Appendix D	Function Code Reference	97
	Commands to control print style	
	Commands to control vertical position of print head	
	Commands to control horizontal positions of print head	
	Other command	
Appendix E	Secondary Address Reference	105
Appendix F	Technical Specifications	109
	Consumer Response	

CHAPTER 1

SETTING UP YOUR PRINTER

In this chapter, we'll show you how to unpack your new printer, set it up in the right location, and get it ready for you to load it with paper and start printing. But first...

WHERE SHALL WE PUT IT?

Before you do anything else, give some thought to where you'll be using your printer. Obviously, it will be somewhere near your computer. And both printer and computer will lead longer, healthier lives if they like their environment. For instance, we recommend...

- Placing the printer on a flat surface
- Keeping it out of direct sunlight and away from heat-producing appliances
- Using it only in temperatures where you are comfortable
- Avoiding areas with a lot of dust, grease, or humidity
- Giving it "clean" electricity. Don't connect it to the same circuit as large, noise-producing motors
- Power supply voltage should be the same voltage that's specified on the identification plate — not over 10% more or less than the recommended AC voltage.

Warning: Extremely high or low voltage can damage your printer.

WHAT HAVE WE HERE?

Now let's take a look at what's in the carton. Take it slow and easy, and check each item in the box against Figure 1-1. There should be exactly 8 items.

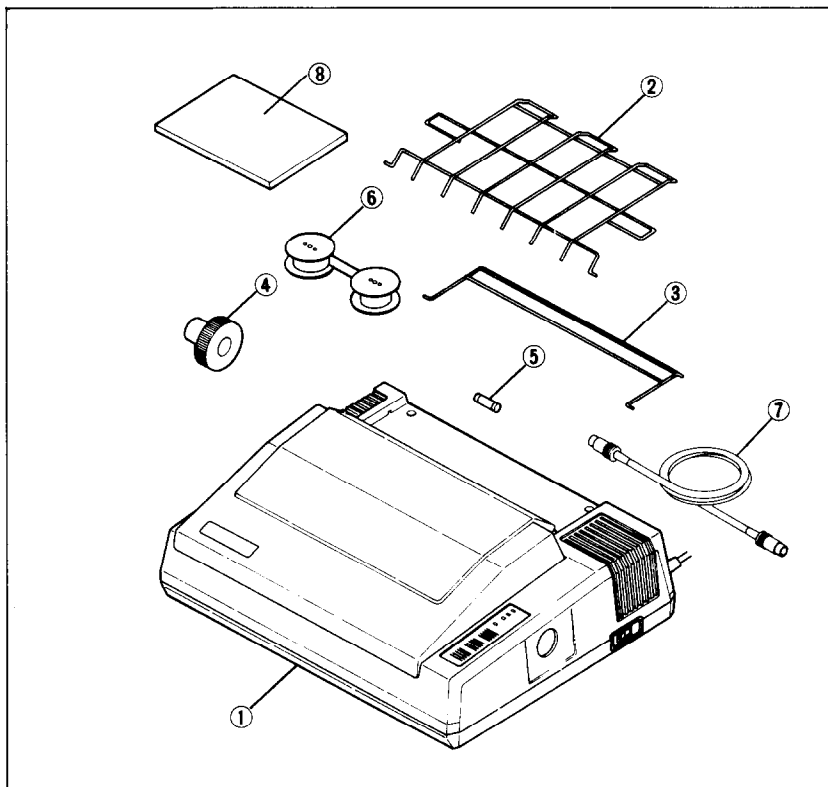

Figure 1-1. Inside the carton you should have received: 1) printer, 2) paper separator, 3) paper guide, 4) platen knob, 5) spare fuse, 6) ink ribbon, 7) interface cable, and 8) this user's manual.

Let's move on the next step.

■ Removing the printer cover

What is cover for, really? Primarily, for two reasons: one, to keep dust and dirt away from the delicate "innards," and two, to keep the noise level down. So you should keep the cover on all the time, except when setting the ink ribbon in place, loading paper, or making other adjustments when the cover might be in the way.

To remove the printer cover, lift up the front end, and pull out the two tabs at the back edge of the cover from the two slots of the case, and off the machine. To replace, just reverse the procedure. Figure 1-2 illustrates the proper position and movement for both removal and replacement of the cover.

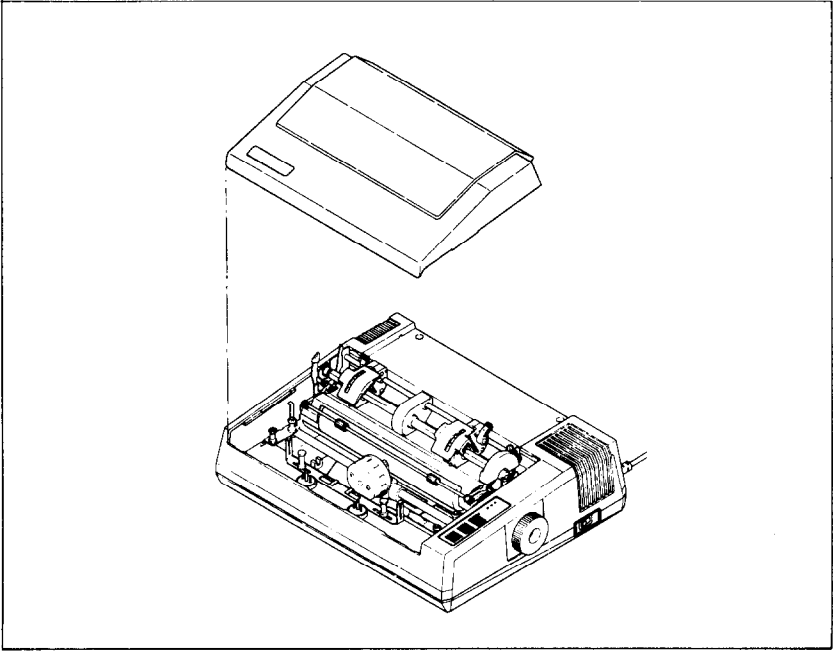

Figure 1-2. Remove the printer cover by lifting carefully.

■ **Removing packing and shipping screws**

There are two shipping screws on the bottom of the printer, used to hold the internal chassis securely to the external frame during shipping. To get at these, carefully place the printer upside down on a soft surface like a foam cushion. Remove the screws with a Phillips screwdriver as shown in Figure 1-3.

Next, remove the printer cover, and remove the spiral tube on the carriage stay which protects the print head, per Figure 1-4.

You'll be smart to save these screws, along with the rest of the packing material and the shipping carton, in case you ever have to ship the printer. Tape the screws somewhere on the carton or packing.

■ **Installing the platen knob**

This is the knob that turns the rubber platen cylinder. It fits into the hole on the right side of the printer case. Just match the odd-shaped hole in the knob with the same shape on the shaft you'll see inside the hole in the case, and press it on firmly. Give the knob a few turns to see that it's turning the platen easily and smoothly.

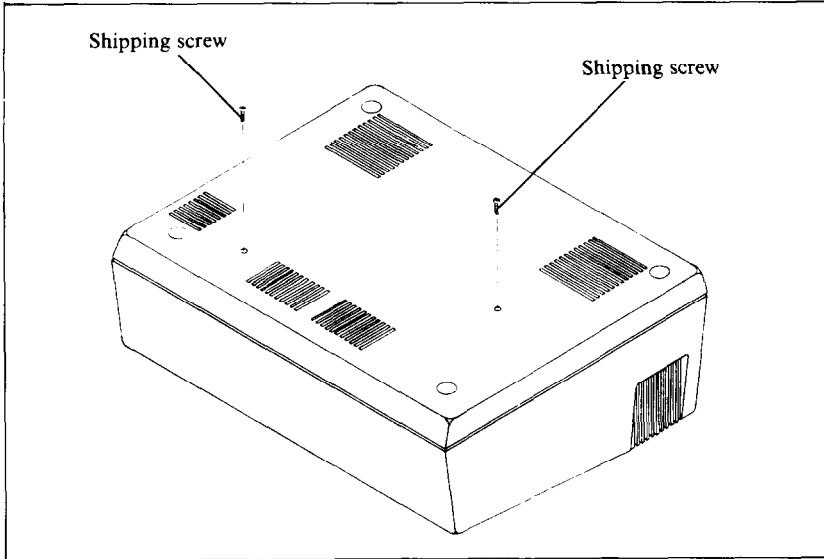

Figure 1-3. The printer has two screws which secure the chassis during shipping. They should be removed before use.

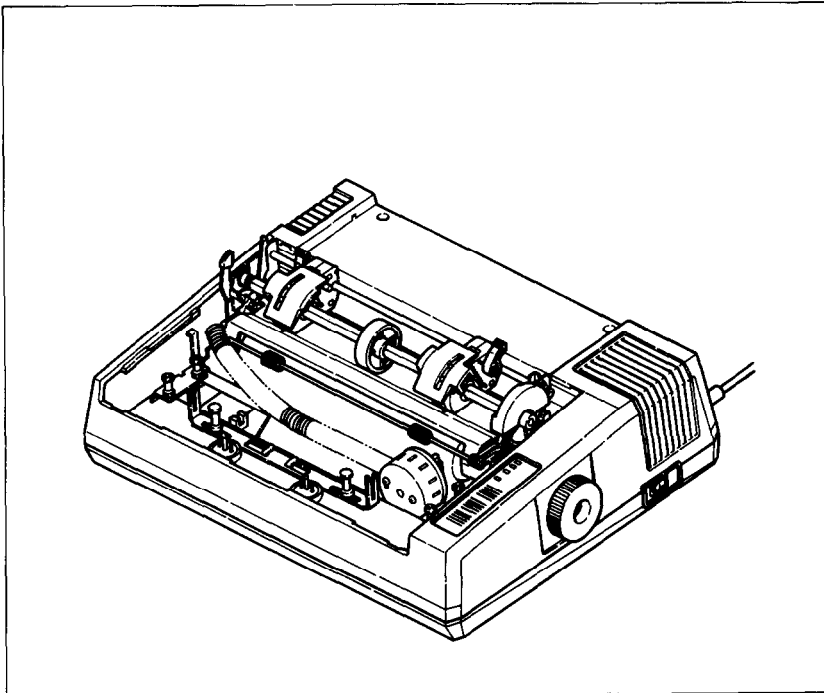

Figure 1-4. Remove the spiral tube on the carriage stay that protects the print head.

■ Removing the tractor unit

The tractor unit, shown in Figure 1-5, comes mounted on the printer during shipment. It is used only with sprocket-feed paper. When other papers are used, such as single sheets, the unit should be removed, in the following manner:

Remove the printer cover (if attached).

Identify the "snap levers" as shown in Figure 1-5.

Pull both snap levers forward, and at the same time...

Rock the tractor unit up and towards you about half an inch.

Now lift the tractor up and away from the printer.

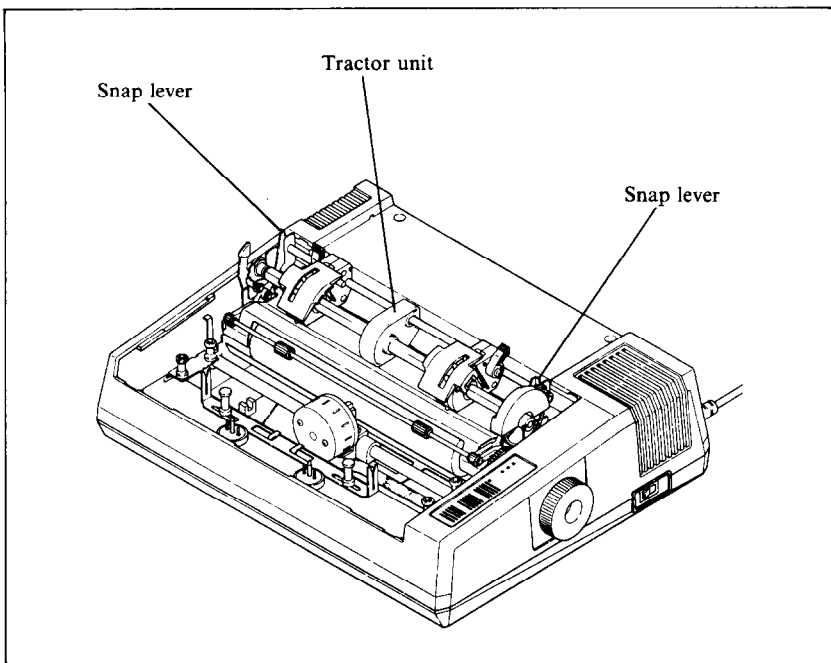

Figure 1-5. Remove the tractor by pulling the snap levers towards you and tilting the tractor unit back.

Up to this point, we've been clearing the decks for action, so to speak. Only two more things are left to do before we can start printing. They are, 1) attach the paper separator and guide, and 2) install the ink ribbon. Actually, if you're planning to print on single sheets only, you won't need to use the paper separator and guide, which are designed expressly to guide continuous paper (sprocket-feed) through the printer.

■ Attaching the paper separator and paper guide

First, identify the paper separator (the large metal rack), shown in Figure 1-6. Insert one protruding end into the hole shown in the diagram, then gently bend the other protruding end until it snaps into the opposite hole. Follow the same procedure with the smaller metal rack, which is the paper guide.

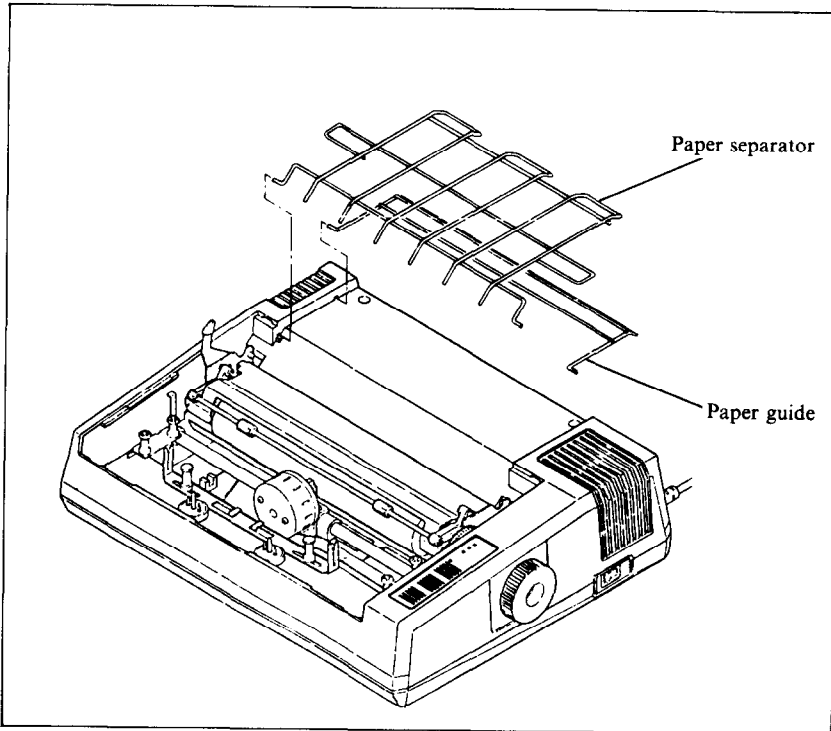

Figure 1-6. Attach the paper separator and paper guide.

Important news: If you get these in upside down, they won't work. So take another sharp look at Figure 1-6 before we pass on to the final act – installing the ink ribbon.

■ Installing the ribbon

Telling you how to set the ribbon is like writing a set of instructions on how to tie your shoelaces. It takes a lot longer to describe it than it does to do it! So, you'll be smart to study the several figures shown here; they'll tell you all you really need to know.

Nevertheless, if you feel better following written instructions, read on...

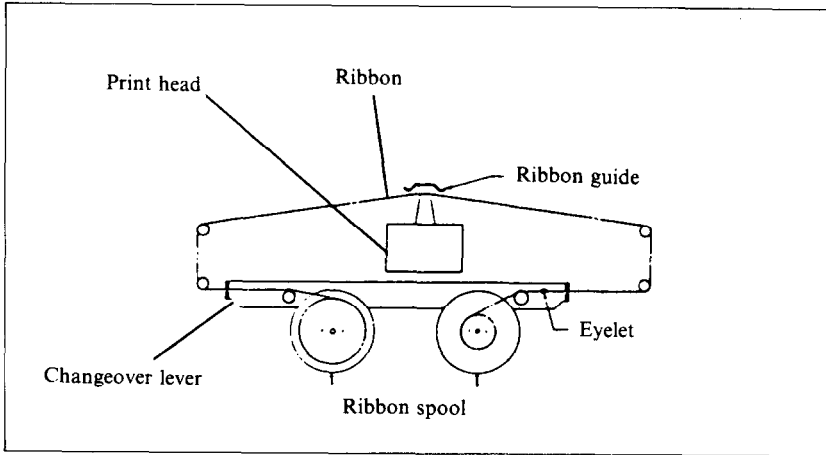

Figure 1-7. You'll find this diagram of the ink ribbon path inside your printer for easy reference when you change ribbons.

After looking carefully at the Figure 1-7, begin by turning the power *off*, and removing the printer cover. Then slide the print head gently to the center of the printer. Next, set one of the ribbon spools on a ribbon spool post, being careful to have it wind/unwind exactly as shown in the figures. The spool should fit so that the drive pins engage the spool.

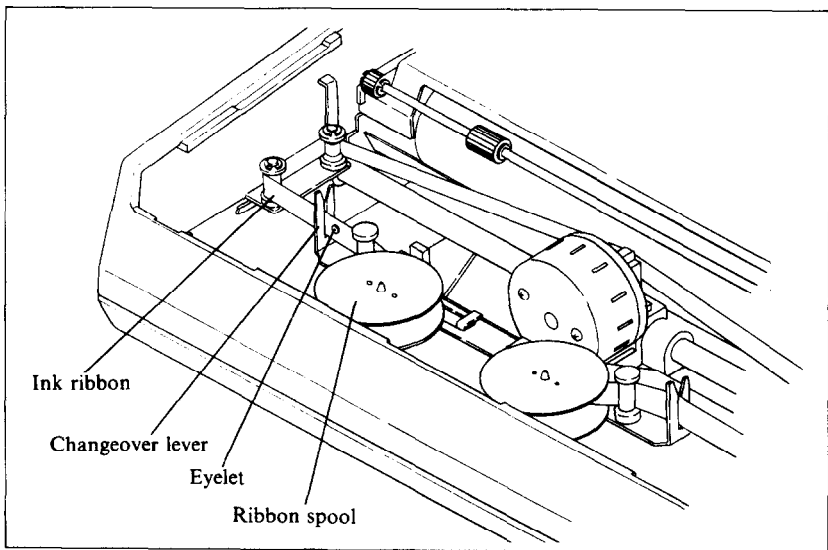

Figure 1-8. The eyelet should be between the ribbon spool and the changeover lever.

Next, you start threading the ribbon. The only tricky part is around the print head, so pay particular attention to Figure 1-9. The ribbon should fit in the slot between the print head and the ribbon guide. Use a ballpoint pen to work the ribbon down between the print head and the ribbon guide.

The other thing to watch is the position of the eyelet near the end of the ribbon. This works exactly like a typewriter ribbon eyelet; it can't get by the slotted guide, which causes the ribbon to automatically reverse its direction.

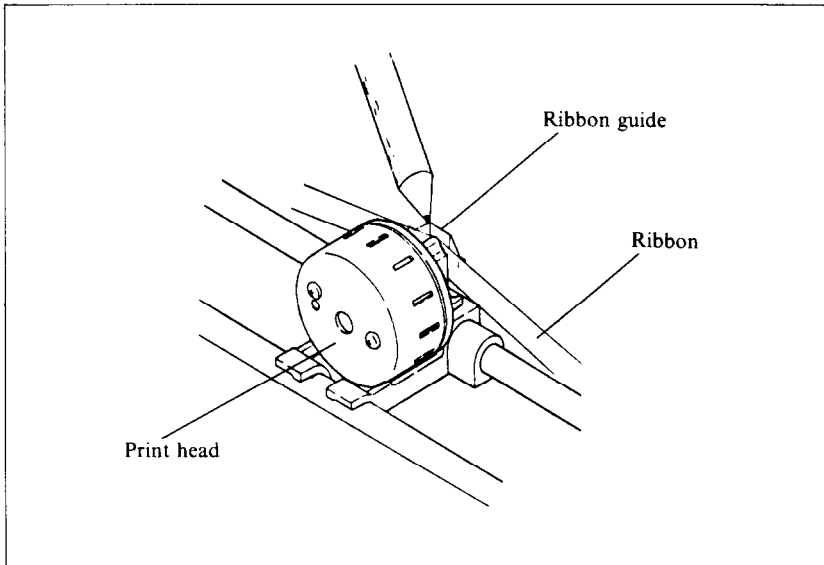

Figure 1-9. You may want to use a ballpoint pen to press the ribbon guide toward the platen and work the ribbon down beside it.

Finally, set the other spool snugly on the opposite spool holder; then turn the spools by hand four or five turns in each direction to verify that everything is properly set and ready to roll.

CHAPTER 2

GETTING TO KNOW YOUR PRINTER

The more you learn about this printer and its sophisticated features, old and new, the better printer is going to perform for you. Remember, it's not just what you know—it's what you know *how to use!* So, let's start getting acquainted!

Subjects we'll cover in this chapter include:

- **Components and controls**
- **Paper-out detector**
- **Paper selection and loading**
- **Adjusting the gap— for different paper thickness**
- **Self-test— printout of available characters**

COMPONENTS AND CONTROLS

First, the components. You saw most of these when you unpacked your printer. Now we'll give you a brief explanation of what they do. (For details on your initial set-up of this printer, with all components in place, see Chapter 1.)

PRINTER COVER—This function is to protect the ribbon and print head from dust and dirt, and also to reduce the sound level.

PAPER SEPARATOR and PAPER GUIDE—As you've guessed, these wire racks are used to support and guide the sprocket paper during printing.

POWER CORD—Connects the printer to its power source, usually a wall outlet. It's located at the left rear.

PRINT HEAD—This is the unit which does the actual printing. Like a typewriter, the print head prints through an ink ribbon.

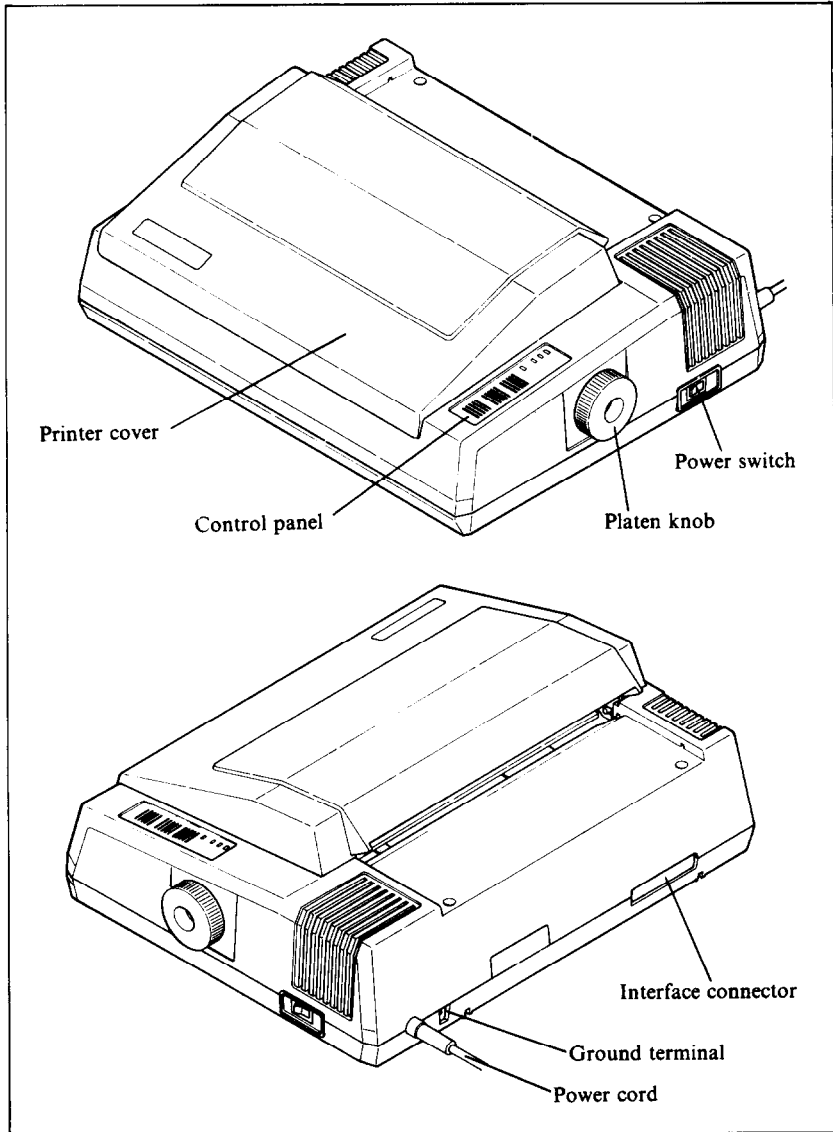

Figure 2-1. Front and rear views of the printer

TRACTOR—This unit feeds sprocket-feed paper with its drive gear and sprocket units. It is very easy to remove or to install the tractor unit onto the printer.

PLATEN—This is the rubber cylinder that carries paper to the print head.

INTERFACE CONNECTOR—Around on the back, this is the place where you connect your computer to this printer, so that they are able to communicate with each other.

Now let's take a tour around the controls, starting with the control panel board, located at the right front. There are 4 lamps and 3 buttons on the panel:

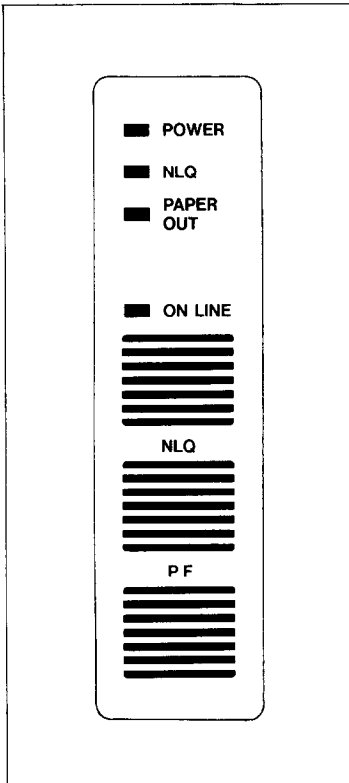

Figure 2-2. Control panel

POWER LAMP—Glow green when the power is *on*.

NLQ LAMP—Glow green when the printer is selected the Near Letter Quality (NLQ) mode by the NLQ button or the DIP switch.

ON LINE LAMP—Glow green when the communication lines to your computer are open.

PAPER-OUT LAMP—Glow red when the printer is out of paper and stops printing.

NLQ BUTTON—Lets you change the printer mode between the "Draft" mode and the "NLQ" mode. When it's "NLQ" mode, the NLQ lamp glow green.

PF BUTTON—Stands for "Paper Feed", and allows you to advance the paper one line at a time when the ON LINE lamp is off. If you hold the button down, you'll get to advance the paper to the top of a new page or "form".

ON LINE BUTTON—Lets you change the printer status between "off line," and "on line". When it's on line, the printer can receive data from the computer. When it's off line, the printer sends a signal to the computer indicating that it cannot accept data. When you turn the power switch *on*, you are automatically on line.

CAUTION: Do not put your printer to the off line while using your computer system.

There are other kinds of controls, not connected to the control panel board. Some of the more important ones are:

POWER SWITCH—Towards the back on the left side. This turns on the electricity to your machine.

PLATEN KNOB—Middle, right side. Lets you manually turn the platen, just like a typewriter. **CAUTION:** Turn this knob only with power switch *off*. Turning it with the power on could damage the platen drive gears.

RELEASE LEVER—On top, near the left rear corner. You'll be using this particular control often. What it does is control the pressure of the paper against the platen. Its position is crucial to feeding the different paper types—sprocket and single sheets. It has two settings: "Friction," and "Tractor." The Friction position is used for single sheet printing, and the Tractor position for sprocket paper. This will be fully explained in the section describing paper loading procedures.

PAPER BAIL—The bail is the movable bar that presses the paper against the platen during printing, and when moved away from the platen, allows the paper to reach its proper position during the loading operation.

PAPER-OUT DETECTOR—This sensor automatically stops printing and tells you when the printer runs out of the paper. The paper-out lamp glows red and a beep tone alerts you when the printer runs out of paper. The on line lamp also goes off, so you are ready to load more paper.

DIP SWITCHES—Primarily, these switches are used in interfacing this printer to your particular brand of computer. But there are also switches to set the power-on default settings for print style, and page size. See the appendix for a complete explanation.

PAPER SELECTION AND LOADING

That's it for components and connectors. The next thing we'll look at is the variety of papers available for this printer, and how to load them, ready to print. For starters, this printer can handle single sheets—whether standard-size stationery, envelopes, multi-part carbonless business forms, or almost any other kind of individual sheets. You can also print on continuous paper—fan-folded perforated paper.

Here's a good place to spend a minute talking about the re-

lease lever, which you'll be using often. This lever controls the pressure of the paper against the platen. It has two settings – "F" and "T".

The "F" setting stands for "Friction Feed" and this setting is always used when running single sheets. The "T" position stands for "Tractor Feed" and is used only with sprocket-feed paper. "F" tightens the pressure of the paper against the platen, while "T" loosens this pressure, so it's easier to move the paper around.

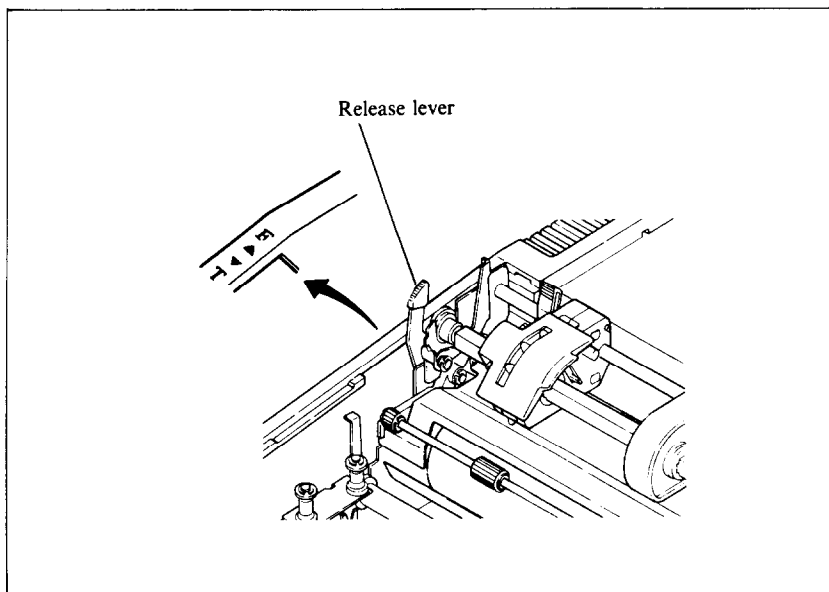

Figure 2-3. The paper release lever has two settings: "F" for friction feed and "T" for tractor feed.

■ Loading single sheets

Paper width must always be between 8 and 10 inches, and paper thickness between .07 mm and .10 mm.

Now, instead of rolling the paper in *manually* by turning the platen knob, we're going to use the PF button, with the power switch turned *on*. (This means we'll have to use the "F" (friction feed) position of the release lever.) Remember what we told you about that PF (paper feed) button? This allows you to advance the paper one line at a time, and if you hold the button down, you'll get multiple line feeds.

OK? Now let's start.

1. Remove the printer cover and tractor unit (you can leave the paper separator on if you have installed it).
2. Turn the power switch on.
3. Lift up the paper bail bar.
4. Set the release elver to the "F" position.
5. Insert the sheet from the back side of the platen (between the paper chute and the platen cover plate).
6. Press the ON LINE button until the ON LINE light goes off.
7. Tap on the PF button to roll the paper in until it appears on the front side of the platen, about where you want the first line to start printing.

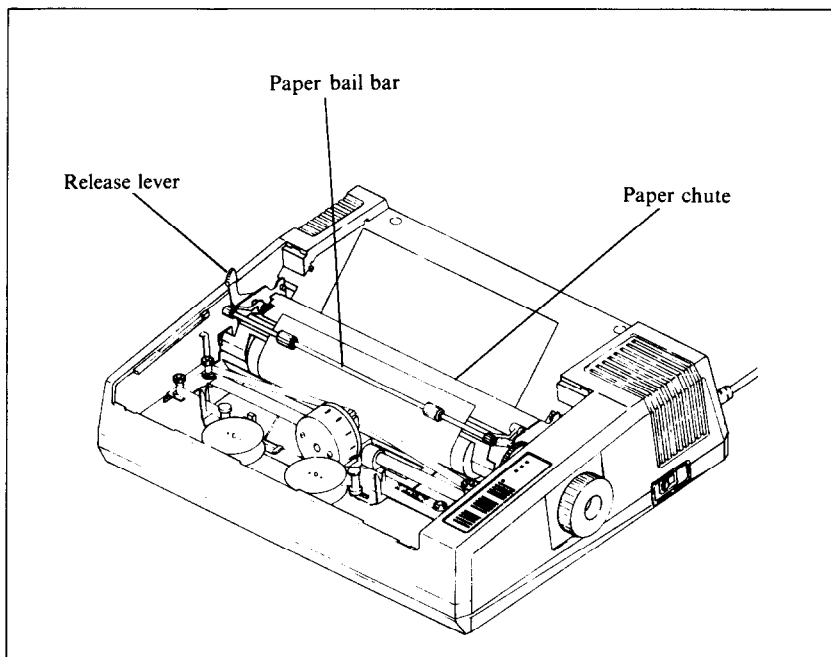

Figure 2-4. Inserting a single sheet of paper can be done "under power" with the line feed button.

NOTE: To straighten paper (if it's in crooked):

- Move the release lever to "T" position.
- Position the sheet where you want it, moving right or left if necessary to get the paper located between the margins of the printing area.
- Move release lever back to "F" position.

8. Push the paper bail bar back to its original position, flush against the paper.
9. Replace the printer cover.
10. Presto! You're ready to start printing!

■ Loading sprocket-feed paper

This is the familiar perforated paper, with the holes along both sides, also called sprocket, punched, fan-fold, or just plain "computer paper." It can be as narrow as 3", and up to 10" wide.

To use this kind of paper, you'll need to install the tractor unit, with its two "sprocket" wheels to carry the paper along.

To install the tractor, identify the two "snap levers" shown in Figure 2-5. At the same time, identify the two "stoppers," nickel-plated bars over which the hooked or cut-out bottom edge of the tractor frame fits.

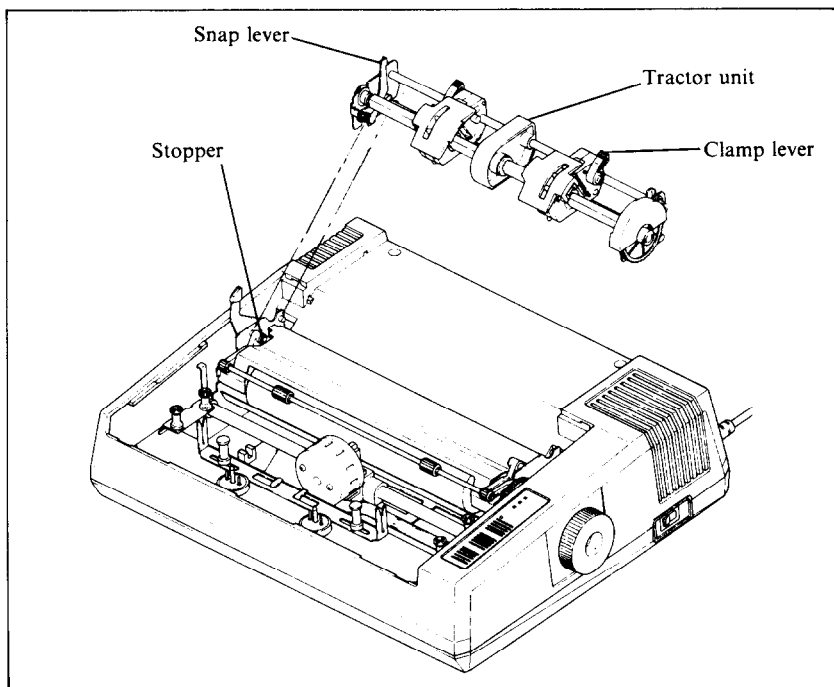

Figure 2-5. Replace the tractor unit by placing the hooks against the stoppers and lower the front into place while holding the snap levers.

OK? Now pick up the tractor unit. While depressing the two snap levers, guide it down to the two stoppers; when the hooks slide over the stopper bars, let go of the snap levers to lock it in place.

Next, if you haven't already, install the paper separator (see Chapter 1), and we're ready to start loading.

1. Turn the power switch off and open the printer cover.
2. Pull the release lever (on left side) to position "T".
3. Raise the paper bail bar; lift the paper separator upright.
4. Place the stack of fan-fold paper behind the printer.
5. Open the tractor covers, atop the right and left sprocket units, as shown in Figure 2-6.

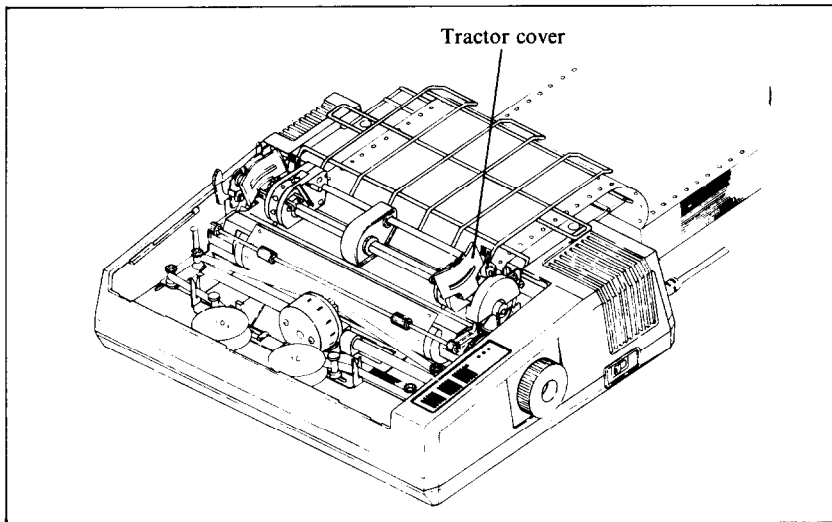

Figure 2-6. Open the tractor covers to expose the sprocket teeth.

6. Flip the clamp levers forward. This allows the two sprocket units to move freely right and left, so you can align them with the holes in the paper.
7. Pick up the top sheet, and feed it between the paper chute and platen cover plate.
8. Push the paper down and forward, so it wraps around the platen.
9. Return the paper separator to its original flat position.
10. Pull the paper up, past the sprocket units.

11. When holes fit snugly over the nubby teeth in both sprockets, close the tractor covers and snap the clamp levers back into their locked position (Figure 2-7).
12. With the platen knob, roll the paper up or down until the correct "start-print" position is reached. You do this by lining up the horizontal perforation (where you tear apart individual sheets) with the top of the ribbon guide.
13. Now you're ready to roll! Replace the printer cover and turn the power switch on. Rapid printing!

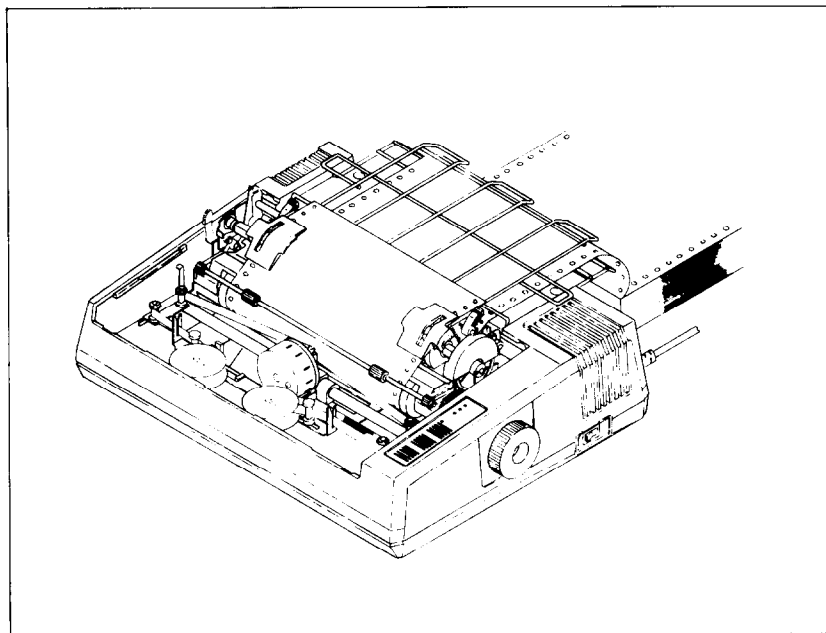

Figure 2-7. Ready to run with sprocket-feed paper.

ADJUSTING THE GAP

The gap is the space between the print head and the platen. Adjusting the gap is simply adjusting the printer to accommodate different thicknesses of paper.

To make this adjustment, move the adjustment lever which is under the printer cover, immediately in front of the release lever shown in Figure 2-8. Pulling the adjustment lever towards you will widen the gap; pushing it away from you will narrow the gap.

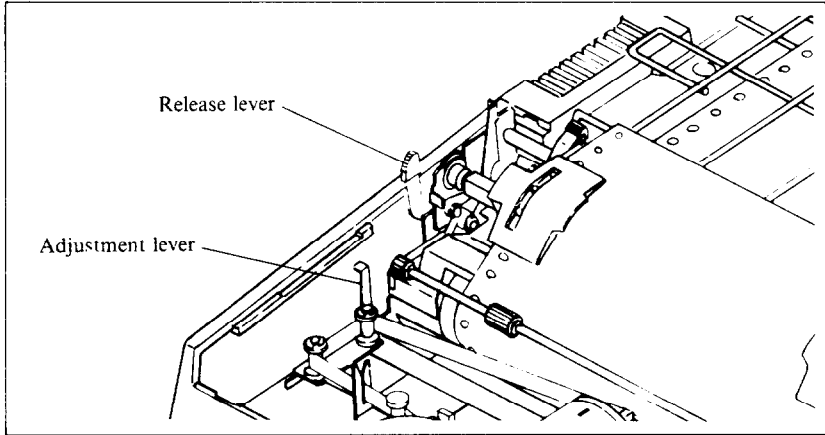

Figure 2-8. The adjustment lever allows for different thicknesses of paper.

Five positions are available; you can feel the lever clicking into the various notches. The second step (illustrated) is the one most commonly used for single sheets of paper. The lever is nearly straight up in this position.

You shouldn't encounter any difficulty in finding the right gap setting to fit your paper. If necessary, experiment; you'll soon find the best position for the paper you're using.

SELF-TEST

The "self-test" is a trial run of your beautiful new machine. This printer carries a built-in program that prints out sample lines of letters, numbers, and other characters—to show you that everything's in good working order. It also serves as a display of the characters available in the printer. And finally, it's a "warm-up" that permits you to check your installation of ribbon and paper, and the adjustment of the print head gap.

Best of all, you don't have to wait another minute—you can print the self-test without hooking up the printer to your computer! It's as simple as 1, 2, 3...

1. Plug the printer's power cord into an electrical outlet.
2. Insert a sheet of paper (or sprocket paper, either one).

MEMO

CHAPTER 3

GETTING STARTED WITH YOUR PRINTER

You have assembled and tested your printer, and seen a quick sample of the capabilities of this printer in the self-test. Now, it's time to do what you bought this printer to do: print information from your computer.

But first you need to connect the printer to your computer. Please follow the instructions in the order listed below.

1. Make sure that both your computer and printer are turned OFF.
2. Connect one end of the 6-pin DIN cable to either of the two connector sockets located in the back of your printer. This cable is "keyed" so that you cannot connect the cable in the wrong way. This means that the pins should be positioned so that a slight pressure will insert the cable properly. You should not have to force these pins in, and doing so could damage your cable.
3. Connect the other end of the cable to your computer in the Serial Port Connector located in the back of your computer. Make sure that you are "keying" the pins properly into the connector with 6 holes.

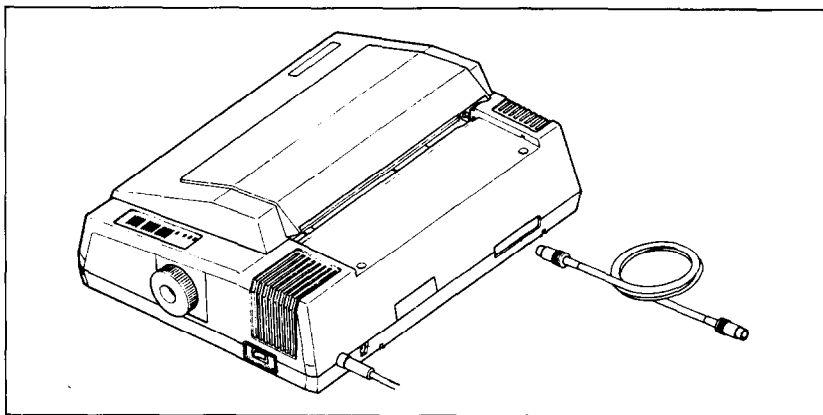

Figure 3-1. Connecting the cable.

■ First, some terminology

This printer knows what to print because it knows how to interpret the codes that the computer sends to it. These codes are numbers that the computer sends to the printer. Both the computer and printer know the meaning of these codes because they are a set of standard codes used by almost all microcomputers. This set of codes is the *American Standard Code for Information Interchange*, which is usually referred to as ASCII (pronounced *ask-key*). There are ASCII codes for all the letters of the alphabet, both lower case and capital, the numbers from 0 to 9, most punctuation marks, and some (but not all) of the functions of the printer.

ASCII codes are referred to in several different ways, depending on the way they are used. Some times these codes are treated as regular numbers. For example, the letter "A" is represented by the number 65 in ASCII. Appendix B shows all of the ASCII codes.

In BASIC, ASCII codes are used in the CHR\$ function. This function is used to print the character that is represented by the number in the CHR\$ function. The BASIC statement PRINT CHR\$(65) will print an "A" on the terminal.

In some other programming languages, ASCII codes are referred to by their *hex* value. "Hex" is short for *hexadecimal* which is a base-16 number system (our usual numbers are base-10). Since hex needs 16 digits, it uses the numbers 0 through 9 and then it uses the letters A through F for digits. The ASCII code for the letter "A" is 41 in hex.

Of course, most of the time we don't even need to think about this code system. Our computers are smart enough to know that when we press the "A" key on our keyboard we want to print the letter "A". The computer takes care of all the rest.

But there are a number of ASCII codes that don't have keys on the keyboard. The most important of these codes are the codes that have ASCII values below 32. These codes control many of the printer's functions. Even though there aren't keys for these codes, most keyboards can send these codes. It's done by holding down the "control" key (many times marked CTRL) and simultaneously pressing a letter key. The particular letter key that is pressed determines what code is sent. Control and A sends ASCII code 1, control and B sends ASCII code 2, and so on. Because of the way they are created, these codes are often referred to as "control-A" etc.

So there are four common ways of referring to the same set of codes: the character or name of the code, the decimal ASCII value, the hexadecimal ASCII value, and the "control-" value.

For example, the code that causes the printer to advance the paper one line is ASCII 10 (decimal). This code is commonly referred to by all the following names:

line feed	—	its name
<LF>	—	the abbreviation of its name
ASCII 10	—	its decimal value
ASCII 0AH	—	its hexadecimal value (the H signifies hex)
CHR\$(10)	—	the way it's used in BASIC
control-J	—	the way you send it from a keyboard.

There's a chart in Appendix B that shows these side-by-side so that you can convert back and forth.

The reason that we are telling you all this about ASCII codes is that people are not very consistent about how they describe ASCII codes.

■ Using this book without learning BASIC

Throughout the latter part of this book we will be teaching you how to use all of this printer's features using the BASIC programming language in our examples. This is because it is easy to communicate with the printer from BASIC and because, despite its shortcomings, BASIC is the nearest thing to a universal language among users of personal computers. But it's not the only way to communicate with the printer. Even if you don't know BASIC, you can learn how to use this printer's features by reading on. When you find a function that you want to use, just apply what you already know about translating from one name for codes to another. The examples will still show you how the commands are used, even if you are not using BASIC.

MEMO

CHAPTER 4

CONTROLLING PRINTER WITH BASIC

Throughout the rest of this book will be teaching you how to use the features of this printer using the BASIC programming language in our examples. It is easy to communicate with this printer from BASIC and, though it has its detractors, BASIC is the nearest thing to a universal language among users of personal computers. But remember that it's not the only way to communicate with this printer, as we have already seen.

Subjects covered in this chapter include:

- **Basic commands associated with your printer**
- **Printing from BASIC**
- **CHRS function**

All of the examples in this manual are written in Commodore BASIC (specifically, Commodore BASIC for the Commodore C-64 Computer). In this chapter we assume that you have some familiarity with BASIC.

SOME BASICS ABOUT BASIC

Probably the simplest thing to do with your printer in BASIC is to list a program on the printer. But in this world of proliferating microcomputers even this presents a problem. It seems that every computer uses a different system of communicating with the printer. We are going to tell you about some of the more common ways, and hope that between this and your computer's BASIC manual you will be able to stay with us.

■ **The OPEN command**

When you want to print on the printer, you must first open the printer as a device. You can this by typing:

OPEN *lfn*, *dn*, *sa*

This command sets a correspondence between a file number and a physical device. The *lfn* or logical file number may be any number you choose to assign to your file from 1 to 255. It doesn't matter which number you choose as long as you remain consistent throughout your set of commands. The *dn* or device number (also known as the primary address) refers to the device to which you wish to send the file. In case of the printer, the number must be 4 since that is the number assigned to it at the factory. The *sa* or secondary address is used to specify a particular printer function. Secondary addresses are thoroughly in the following chapters.

■ The CMD command

This statement transfers the primary output device (screen) to the logical number specified in the command. The file must have been OPENed. When this command is in effect, all output generated by PRINT or LIST command will be sent to the file instead of the screen. The format of the command is as follows:

CMD *lfn*

The *lfn* must be the same as in the OPEN statement with which it is associated. Unlike a PRINT command, the line or bus to the receiving device is left open. The line or bus to the receiving device (in this case, the printer) is said to be "listening".

To re-direct the output back to the primary output device, the PRINT# (not abbreviation) command must be used to send a blank line to the CMD device prior to closing the file. If a SYNTAX ERROR occurs, output will not be redirected back to the screen. Devices are not "unlistened" by this so you should PRINT# a blank line after an error condition.

■ The PRINT# command

PRINT# command works just like the PRINT command except that it directs output to the printer instead of the screen. After printing the designated data, the line or bus to the printer is said to be "unlistened". Therefore, if you have used the CMD command, it is necessary to follow it with a PRINT# command in order to "unlisten" the connection between the printer and the computer. The syntax of the PRINT# command is:

PRINT# *lfn*, *data*

■ The CLOSE command

You should always close a file after printing to it with the following command:

CLOSE *lfn*

You may not exceed ten files, so you should make a habit of closing files when you are finished with them. This way you will always have the maximum number of files available for use.

■ Establishing communications

We've learned something about communicating with our printer. Now we need to adapt what we know to printing in a BASIC program. Generally, computers use about the same procedure for printing in a program as they do to list a program.

Let's try what we learned. Type the following:

```
NEW
10 OPEN 4,4
20 PRINT#4, "TESTING"
30 CLOSE 4
RUN
```

You should have the word "TESTING" on your printer. Quite an achievement, isn't it? Let's get done with this simple stuff so that we can go on to something interesting.

■ The CHR\$ function

We mentioned CHR\$ in Chapter 3 as one way to express ASCII codes. We are going to use it a lot in communicating with this printer. This printer uses many of the ASCII code that don't represent letters and numbers. The CHR\$ function gives us an easy way to send these codes to the printer. Try this to see how the CHR\$ function works:

```
NEW
10 OPEN 4,4
20 PRINT#4, CHR$(83)
30 CLOSE 4
RUN
```

That should print an “S” for Star. If you check the chart in Appendix B you will see that 83 is the ASCII code for “S”.

■ Control codes

This printer uses many of the non-printing ASCII codes for control codes. These codes perform a function rather than printing a character. Let’s try an easy one right now:

```
NEW
10 OPEN 4,4
20 PRINT#4, CHR$(7)
30 CLOSE 4
RUN
```

Where did that noise come from? That’s the printer’s bell. We will learn more about it in Chapter 8. We just wanted to illustrate a code that causes the printer to perform a function.

CHAPTER 5

PRINTING TEXT WITH PRINTER

Beginning with this chapter we will be exploring all the features of this printer

In this chapter we'll cover:

- **Near letter quality characters**
- **Italics**
- **Print pitch**
- **Print emphasis**

All our examples will be given in Commodore BASIC as used by the Commodore C-64, but remember that you don't need to know BASIC to use this printer's features. Just use the same ASCII codes as we do in our examples.

You have already printed a few lines on your printer. Now it's time to start looking at the many variations of printing styles you have available to you.

SOME SPECIAL KINDS OF TEXT

■ **Near Letter Quality characters**

This printer's Near Letter Quality (some times abbreviated as NLQ) character set is ideal for correspondence and other important printing, for it takes a keen eye to detect that it is from a dot matrix printer. Normally (unless you have turned on the NLQ lamp on), this printer prints draft quality characters. This is adequate for most work and it prints these the fastest. But for the final printout, try NLQ.

It is very easy to select the NLQ characters.

Push the ON LINE button to turn off the ON LINE lamp, then push the NLQ button to turn on the NLQ lamp.

You can also select the NLQ characters as the power-on default by turning the DIP switch 1-4 off.

NEAR LETTER QUALITY CHARACTERS
ARE PRINTED WHILE THE NLQ LAMP GLOWS.

■ Italic printing

Italic letters are letters that are slanted to the right. Your printer can print all of its letters except NLQ characters in *italic* as well as the roman (standard) letters you are accustomed to.

To select the italic characters, turn off the DIP switch 1-2 while the power is down. If you select the NLQ characters while in the italic mode, the characters are printed in the roman NLQ characters.

ITALIC CHARACTERS ARE PRINTED
WHEN THE DIP SWITCH 1-2 IS TURNED OFF.

■ Emphasized printing

Your printer has very good print density when it's just printing regularly. But sometimes you may want to print darker. This printer provides the emphasized characters by setting the DIP switch 1-5 off.

THIS IS EMPHASIZED PRINTING WITH
THE DIP SWITCH 1-5 IS TURNED OFF.

CHANGING THE PRINT PITCH

In "printer talk" character width is called *pitch*. Normally, this printer prints 10 characters per inch. This is called *pica* pitch because it's the same as a standard pica typewriter.

This printer can also print 17 characters per inch. This is called condensed pitch, and allows you to get 136 columns of printing on an 8½ inch page.

You can select the pitch whichever you wish by turning the DIP switch 1-3 while the power is down.

THIS LINE IS PRINTED WITH PICA PITCH WHILE
THE DIP SWITCH 1-3 ON.

THIS LINE IS PRINTED WITH CONDENSED PITCH WHILE THE DIP SWITCH 1-3 OFF.

PRINTING WITH CONTROL CODES

Up until now, we have introduced controlling with DIP switch settings. The rest of this chapter, we will show you printing text with control codes.

■ Expanded print

Each of this printer's two print pitches can be enlarged to twice its normal width. This is called expanded print. Try this program to see how it works:

```
10 REM DEMO EXPANDED MODE
20 OPEN 4,4
30 PRINT#4, "NOTICE THAT"
40 PRINT#4, CHR$(14);
50 PRINT#4, "EXPANDED MODE STAYS ON"
60 PRINT#4, "UNTIL IT IS"
70 PRINT#4, CHR$(15);
80 PRINT#4, "TURNED OFF."
90 CLOSE 4
```

```
NOTICE THAT
EXPANDED MODE STAYS ON
UNTIL IT IS
TURNED OFF.
```

When you turn on expanded print with CHR\$(14) it stays on until you turn it off with CHR\$(15).

Now change your program as shown below to see how your printer will work:

```
10 REM DEMO EXPANDED MODE
20 OPEN 4,4
30 PRINT#4, "EXAMPLE ";
40 PRINT#4, CHR$(14);
50 PRINT#4, "OF ";
60 PRINT#4, CHR$(14);
70 PRINT#4, "EXPANDED";
80 PRINT#4, CHR$(15);
90 PRINT#4, " MODE"
100 CLOSE 4
```

 EXAMPLE OF EXPANDED MODE

Wow, the word of "EXPANDED" is printed in four-times wider than the normal characters.

There's a new little wrinkle in this program, though. It's all printed on one line. The semicolons at the lines told BASIC that those lines were to be continued. Therefore, BASIC didn't send a carriage return and line feed at the end of those lines. And when you send CHR\$(14) again while in the expanded mode, the characters are printed to twice the previous characters.

■ Reverse field print

Your printer can produce the white characters on black ground field. Try this program to see how it works.

```

10 REM DEMO REVERSE FIELD CHARACTER
20 OPEN 4,4
30 PRINT#4, "DEMONSTRATION OF ";
40 PRINT#4, CHR$(18);
50 PRINT#4, "REVERSE FIELD";
60 PRINT#4, CHR$(146);
70 PRINT#4, " PRINTING"
80 CLOSE 4
  
```

In this program reverse field is turned on in line 40 with CHR\$(18), and then off in line 60 with CHR\$(146).

DEMONSTRATION OF **REVERSE FIELD** PRINTING

NOTE: Do not use this mode of printing for more than five consecutive lines since extended printing in this mode will damage the print head.

CHAPTER 6

LINE SPACING AND FORMS CONTROL

We have learned how to print in many different ways, but so far we haven't looked at how to position the printing on the page.

In this chapter we will learn how to:

- Change the vertical spacing
- Change the length of the page
- Creating table

STARTING NEW LINES

Up until now the only time we have thought about printing on a new line is when we *didn't* want it to happen. We learned that putting a semicolon (;) at the end of a BASIC line will not end the line of printing. So, somehow, the computer is telling the printer when to end one line and start another.

There are two codes that are used to end one line and start another. They are *carriage return* (CHR\$(13)) and *line feed* (CHR\$(10)). They have been given abbreviations which you'll find in many texts (including this one); <CR> and <LF>. The codes are simple, but their action is a little confusing. Carriage return is the easiest. Each time that the printer receives a CHR\$(13) it returns the print head to the left margin. It does not advance the paper.

Line feed is more complicated. Each time the printer receives a CHR\$(10) it both advances the paper one line and returns the print head to the left margin, ready to start a new line.

Now to add a little confusion—Commodore BASIC adds a line feed (CHR\$(10)) to every carriage return (CHR\$(13)) that they send. If you want to overprint a line, use CHR\$(141) in-

stead of CHR\$(13). CHR\$(141) does not add a line feed (CHR\$(10)).

CHANGING LINE SPACING

When you turn your printer on, the line spacing is set to 6 lines per inch. This is fine for most printing applications, but sometimes you may want something different. Your printer makes it easy to set the line spacing to whatever value you want.

Try this program to see how easy it is to change the line spacing:

```
10 OPEN 4,4
20 OPEN 6,4,6
30 FOR I=1 TO 40
40 IF I=13 THEN 70
50 PRINT#6, CHR$(I)
60 PRINT#4, "THIS LINE SPACING IS SET TO" I
70 NEXT
80 CLOSE 4 : CLOSE 6
```

Line 20 opens to control the number of steps for line spacing by the secondary address assignment of 6.

The loop that is started in line 30 increases the value of n (the variable I in the program) each time it is executed. So the line spacing increases as the program continues. Line 40 just short-cuts the loop when $I=13$, since BASIC won't let us send CHR\$(13) without adding an unwanted CHR\$(10) to it.

Notice that we used two file numbers in this program because we wanted to perform the formatting control and printing control at the same time. Remember that it is possible to have as many as ten files open simultaneously.

This is what you will get:

```
30 PRINT#4, "LINE NUMBER 2."  
40 PRINT#4, CHR$(12);  
50 PRINT#4, "LINE NUMBER 3."  
60 PRINT#4, "LINE NUMBER 4."  
70 CLOSE 4
```

Before you run the program, turn your printer off and adjust the paper so that the top of the sheet is even with the top of the ribbon guide on the print head, then turn the printer back on. If you don't remember how to do this, review Chapter 2. When you run the program, the results will look like this:

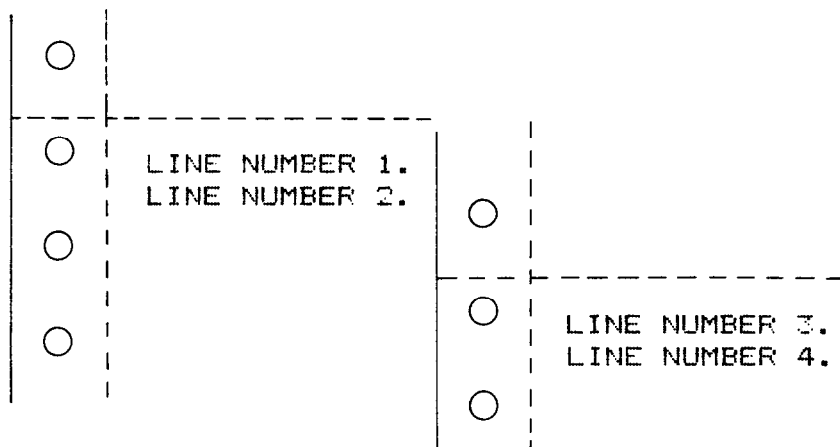

The form feed (`CHR$(12)`) in line 40 caused the printer to move the top of a new page before printing the last two lines.

CHANGING THE PAGE LENGTH

You may have some computer forms that you wish to use with this printer that are not 11 inches high. That's no problem, because you can tell your printer how high the forms are that you are using.

Let's set up a 7 inch high length, which is typical of many computer checks. The following program will do it.

```
10 OPEN 4,4  
20 OPEN 3,4,3
```

```
30 PRINT#3, CHR$(42)
40 PRINT#4, "PAY ORDER OF:"
50 PRINT#4, CHR$(12);
60 PRINT#4, "PAY ORDER OF:"
70 CLOSE 4: CLOSE 3
```

This program should print "PAY ORDER OF:" twice, and they should be 7 inches apart.

We have used the secondary number as 3 in line 20. This special secondary address allows you to vary the printed lines per page. The in line 30, we have sent CHR\$(42) to get the form length to 7 inches while in 6 lines per inch printing. After line 40 prints, line 50 sends a form feed to advance the paper to the top of the next form. Line 60 then prints its message.

After you have run this program, turn off the printer and adjust the top of the form position. When you turn the printer back on the page length will be set to its normal setting (usually 11 inches).

SKIP OVER PERFORATION

Many programs that use a printer don't keep track of where they are printing on the page. This causes a problem when you get to the bottom of a page because these programs just keep on printing, right over the perforation. This makes it very hard to read, especially if a line happens to fall on the perforation. And if you separate the pages then you are really in trouble.

Of course your printer has a solution to this predicament. Your printer can keep track of the position on the page, and advance the paper so that you won't print too near the perforation.

Let's try a simple application to see how this works. Enter this program, which will print 150 lines without skip perforation.

```
10 OPEN 4,4
20 PRINT#4, CHR$(12);
30 FOR I=1 TO 150
40 PRINT#4, "THIS IS LINE" I
50 NEXT I
60 PRINT#4, CHR$(12)
70 CLOSE 4
```

When you run this program it will print 150 lines right down the page and across the perforations. When it's down to line 60, it sends a form feed to advance the paper to the top of the next page. Look at the lines that have been printed near the perforations. Separate the sheets and see if any of the lines have been torn in half. These are the problems that skip perforation will solve.

Now add the following lines to your program. (Don't forget the semicolons or you won't get quite the same results that we did.)

```
15 PRINT#4, CHR$(147);  
55 PRINT#4, CHR$(19);
```

Now when you run the program, it will skip the first three lines and the last three lines on each page. Always send a form feed after setting the top margin, or it will not work on the first page printed. That's because the top margin only takes effect after a form feed.

Line 15 sets the top and the bottom margins to skip the perforations, and line 55 clears both margins when we are done.

○ THIS IS LINE 1
○ THIS IS LINE 2
○ THIS IS LINE 3
○ THIS IS LINE 4
○ THIS IS LINE 5
○ THIS IS LINE 6
○ THIS IS LINE 7
○ THIS IS LINE 8
○ THIS IS LINE 9
○ THIS IS LINE 10
○ THIS IS LINE 11

○ THIS IS LINE 56
○ THIS IS LINE 57
○ THIS IS LINE 58
○ THIS IS LINE 59
○ THIS IS LINE 60
○ THIS IS LINE 61
○ THIS IS LINE 62
○ THIS IS LINE 63
○ THIS IS LINE 64

○ THIS IS LINE 116
○ THIS IS LINE 117
○ THIS IS LINE 118
○ THIS IS LINE 119
○ THIS IS LINE 120
○ THIS IS LINE 121
○ THIS IS LINE 122
○ THIS IS LINE 123
○ THIS IS LINE 124
○ THIS IS LINE 125
○ THIS IS LINE 126
○ THIS IS LINE 127
○ THIS IS LINE 128
○ THIS IS LINE 129
○ THIS IS LINE 130
○ THIS IS LINE 131
○ THIS IS LINE 132
○ THIS IS LINE 133
○ THIS IS LINE 134

MEMO

CHAPTER 7

FORMATTING YOUR OUTPUT

You have probably used the tab and margin features on a typewriter. They make it easier to format the text or chart on a page. Your printer also has the formatting function like tabs and margins, that you can send.

In this chapter we will discover how to use:

- One-time tab setting
- Formatting a table

USING ONE-TIME TAB

Suppose you need to move to a position across the page, but you only need to do it once. It doesn't make much sense to send a group of spaces. There must be an easier way—and of course there is.

The solution is called a *one-time tab* and is `CHR$(16)`. This command moves the print head *n* columns to the right from the home position, depending on the following two digits. Try this program how to see it works:

```
10 OPEN 4,4
20 PRINT#4, "123456789012345678901234567890"
30 PRINT#4, CHR$(16); "10"; "ABCDE"
40 CLOSE 4
```

```
123456789012345678901234567890
      ABCDE
```

It has the same effect as sending 10 spaces in this program.
Now, try another program as shown below:

```
10 OPEN 4,4
20 PRINT#4, "123456789012345678901234567890"
30 PRINT#4, CHR$(16); "10"; "ABCDE";
40 PRINT#4, CHR$(16); "20"; "FGHIJ"
50 CLOSE 4
```

```
123456789012345678901234567890
          ABCDE          FGHIJ
```

You can get two separated characters in your printout. With the CHR\$(16) you can determine the print start position.

FORMATTING A TABLE

Perhaps the most significant feature of your printer is its ability to format data. Picture formatting generates a simple one-to-one correspondence between the column position of the print line and the symbol that is to appear there. Formatting lets you left- or right-justify columns of data, or align numeric data on its decimal point position. Try this program:

```
10 OPEN 2,4,2
20 PRINT#2, "$$$$.99"
30 CLOSE 2
40 OPEN 1,4,1
50 PRINT#1, .05
60 CLOSE 1
```

```
$.05
```

In this program line 10 opens to define the formatting field by the secondary address assignment of 2. And line 20 send the defining data.

Line 40 opens to use the formatting definition by the secondary address assignment of 1.

■ The formatting characters

Specifications of a format are accomplished by a set of formatting characters which, when joined, define the rules of formatting data for the printer format interpreter. The formatting characters may be grouped into three classes:

Numeric	9, Z, \$, S, ., —
String	A
Skip	(Blank)

Fields are specified by combining these formatting characters. Up to 79 characters are accepted in a format string (if you are using condensed pitch, you can accept up to 135 characters). Overflow characters are printed onto the next print line.

The printer software handles up to ten significant figures, and an exponent range ± 99 on numbers passed as data to be formed. Exponential numbers must be normalized such as $0 \leq |X| < 10$.

■ Numeric data

In a numeric field, “9” specifies a digit position. If there is no digit to print in this position, then a blank is substituted.

“Z” also specifies a digit position in a numeric field. Unlike the 9, this character forces a 0 to be printed if there is no digit available for this position. This is desirable if leading zeroes are required in a numeric field.

If one “\$” is specified, then the field is treated as a dollar amount with a fixed-sign position. If all digit positions to the left of the decimal point are \$, then the number is printed as a floating dollar sign to the right, justified before the most significant digit.

When preceding a numeric field, the sign of the number (+ or -) is to be printed in the fixed column position of “S”.

The period character (.) defines the position of the decimal point and is printed literally in this position.

“-” character specifies a trailing sign. If the number is positive, a blank is printed. A numeric field cannot have both S and -. When this is the case, only the S will be honored.

■ String data

The letter "A" represents one position of the string data field. Within the field, leading blanks are truncated, the field is left-justified, and it is padded to the right with blanks. Shifted blanks CHR\$(160), are not deleted if in the leading positions.

■ Skip

Simply use blanks where spaces are required.

■ Literals in format strings

Literals are characters that are to be printed, exactly as they exit, in the printer's memory, rather than being used to format other data. Literals are flagged by preceding each literal in the format string with a reverse-field ON character, CHR\$(16).

One use of literals is to create a special form at the same time you are printing data. This is done by using the special graphics character to form vertical, horizontal, or other lines between the fields. You can create a form while printing data, either by overprinting graphic characters, or by inserting literal characters in a format string.

The only limitation on literal characters in format strings is that they cannot be printed in the reverse field mode. They are also restricted to the same character set in which data is currently being printed.

PRINTING DATA ACCORDING TO A PREVIOUSLY DEFINED FORMAT

Now we are armed to define the formatting field. It's time to tell you how to print a table using the previously defined format. Try this program:

```

100 OPEN 2,4,2
110 F$="ZZZ  AAAAAAAAAAAAAAAAAA    $$$$.99    999"
120 PRINT#2, F$
130 CLOSE 2
140 OPEN 1,4,1
150 A=1
160 B$="ABC PRINTER"
170 C=399

```

```

180 D=140
190 PRINT#1, A, B$, CHR$(29), C, D
200 CLOSE 1

```

When you run this program, you'll get what is shown below.

```

001   ABC PRINTER           $399.00   140

```

In this program, we have defined the format field in line 100 to 130. Then we invoked the formatting features of the printer with the secondary address assignment of 1 in line 140.

When formatting string data from the computer, a skip, CHR\$(29), must be sent to delimit the end of a string being edited to a field. Leading blanks are stripped off a string; therefore, to print a blank string field you must transmit a shifted blank, CHR\$(160). The string field is then right padded with blanks as shown below.

```

10 OPEN 2,4,2
20 PRINT#2, "AAA   AAA   AAA"
30 CLOSE 2
40 OPEN 1,4,1
50 PRINT#1, "ABC" CHR$(29)CHR$(160)CHR$(29) "DEF"
60 CLOSE 1

```

```

ABC           DEF

```

Important: The data to be printed for any formatted line must be sent with only one "PRINT#" command.

MEMO

CHAPTER 8

SPECIAL FEATURES OF THE PRINTER

In the previous chapters we have learned about several groups of control codes. In this chapter we will look at more control codes. These codes don't fit into nearly any of the groupings that we have studied, but they add a lot of capability to your printer. So here goes.

Commands covered in this chapter include:

- **Bell**
- **Master reset**
- **Graphic mode and business mode**
- **Error message**
- **Quotation marks**

■ **Now hear this**

You may have heard the printer's *bell* if you have ever run out of paper. And you may have wondered why it's called a bell when it *beeps* instead of ringing! It's a long history that goes back to the early days of computers, when teletype machines were used for computer terminals. These mechanical marvels had a bell in them that could be heard for blocks. This bell was used to signal to the operator that something needed attention. The code that the computer sent to the teletype machine to ring the bell was, reasonably enough, called a *bell code*. Well the name *bell code* is still with us, even if the bell has changed to a beeper, and a lot of people still call the beeper a bell, even if it doesn't sound like one. So with our trivia lesson out of the way, let's see how we can "ring the bell".

The code to sound the printer's "bell" is `CHR$(7)`, which is ASCII code 7 or `<BEL>`. Any time this printer receives this code it will sound the bell for a quarter of a second. This can be used to remind an operator to change the paper or to make another adjustment to the printer.

■ Initializing the printer

Up to now when we wanted to reset the printer to the power on condition, we have had to turn the printer off and then on again. There is an easier way. The secondary address assignment of 10 will reset all of the printer's features to the power on condition.

■ Graphic mode and business mode

Up until now, we have used the upper case characters in our program samples. But you can use the lower case characters as shown in the self-test function.

Try this short program to see how it works:

```
10 OPEN 7,4,7
20 PRINT#7, "ABC PRINTER"
30 CLOSE 7
```

When you run this program you can get like this:

```
abc printer
```

The secondary address assignment of 7 in this program converts all of the graphic mode characters into the business mode characters.

This is useful when you want to convert all characters into business characters. But sometimes, you may want to print the graphic characters and the business characters in a line. And you can do this with this printer. Try this program:

```
10 OPEN 4,4
20 PRINT#4, CHR$(145); "A"; CHR$(17); "BC ";
30 PRINT#4, CHR$(145); "P"; CHR$(17); "RINTER"
40 CLOSE 4
```

You will get the following printout when you run this program.

```
Abc Printer
```

In this program, CHR\$(145) is used to select the graphic character mode and the CHR\$(17) selects the business character mode.

■ Error message printing

This printer has a special function to show the error statement on your printer. With this function you can recognize the error position.

When a secondary address assignment of 4 is transmitted, the printer's error messages appear whenever an error occurs. When a formatting error occurs, a message is printed, the format is dumped, and a pointer is located at the offending field.

You can cancel this function using the secondary address assignment of 9.

Followings are the error messages under this function.

- *PE: L* Lines per page out of range. An attempt was made to set the lines per page to a value outside the range $13 < \text{lines per page} < 128$ via a print-to-secondary address 3. The command is ignored and the previous length remains in force.
- *PE: C* Bad command. You gave the printer an invalid secondary address outside the range. The command is ignored.
- *PE: M* Data-format mismatch. You gave the printer non-numeric data to print in a numeric field. The first character printed after the error message is the offending character.
- *PE: E* Exponent error. The numeric data given to the printer to print in a numeric field had an invalid exponent. The expected form of an exponential number is: $n.nnnn + ee$ or $n.nnnn - ee$. The expression must contain a plus or minus sign with a two digit exponent.
- *PE: F* Bad format. The data that was sent to secondary address = 2 either contains illegal formatting characters, or unrecognizable syntax.
- *PE: T* Terminator error. The secondary address changed before a terminator was detected. A terminator is defined as a carriage return (CHR\$(13)), a line feed (CHR\$(10)), or a carriage return line-feed se-

quence. Communication with the current secondary address must be terminated with a terminator before attempting to "talk" to another secondary address.

■ Quotation marks

In order to print quotation marks around particular characters, use the character code (CHR\$(34)). When incorporating quotation marks in your program for print statement purposes, use them logically and effectively, do not place any together unless the program design specifically requires it.

```
10 OPEN 4,4
20 PRINT#4, CHR$(34); "ABCD"; CHR$(34)
30 GOSUB 110
40 PRINT#4, CHR$(34); "PRINTERCHR$(34)
50 GOSUB 110
60 PRINT#4, CHR$(34); EFGH; CHR$(34)
70 GOSUB 110
80 FOR I=1 TO 8: PRINT#4: NEXT I
90 CLOSE 4
100 END
110 FOR J=1 TO 2
120 PRINT#4: NEXT J
130 RETURN
```

When you run this program you will get like this:

"ABCD"

"PRINTERCHR\$(34)

" 0 "

Line 20 forms the print routine for "ABCD".

Line 40 will print "PRINTERCHR\$(34)" because both PRINTER and CHR\$(34) are enclosed within their own quotes.

Line 60 will print "0" because the word EFGH is taken as a numeric variable since it is not enclosed within quotes and it's

contents are naturally zero.

If an odd number of quotation marks have been transmitted, control characters are made visible. This can be particularly useful when you are making a listing a BASIC program containing control characters in quotation marks instead of using the CHR\$ function.

MEMO

CHAPTER 9

CREATING YOUR OWN CHARACTER

In the previous four chapters of this manual you've learned how to control the printer to give you dozens of different typefaces. By using various combinations of character weights, and font selections, you can create nearly any effect you want to in text. And with the special text and graphics characters described in Chapter 8, you can print almost any character you can think of.

But if "almost any character" isn't good enough for you, then it's a good thing you have this printer! With it you can actually create your own character. As you'll see in this chapter, download character can be used to print a logo, special characters for foreign languages, scientific and professional applications, or any other specific printing task.

DOT MATRIX PRINTING

In order to create download character, you'll need some understanding of how dot matrix printers work. They're called "dot matrix" because each character is made up of a group of dots. Look closely at some printed characters produced by your printer and you will see the dots. Figure 9-1 shows how the letter "C" is formed by printing 15 dots.

The printhead in this printer consists of nine thin wires stacked one atop of the other. Figure 9-2 shows an enlarged schematic view of the front of the printhead, showing the ends of the wires and their relationship to the printed draft characters. As you can see, the capital letters use the top seven wires of the printhead, and the descenders (such as the lower case "p" shown) use the eight pins. As the printhead moves across the page (in either direction—that's what is meant by bi-directional printing) it prints one column of dots at a time. Each time a dot

is supposed to print an electromagnet inside the printhead causes the appropriate wire to strike the ribbon (making the printer an impact printer).

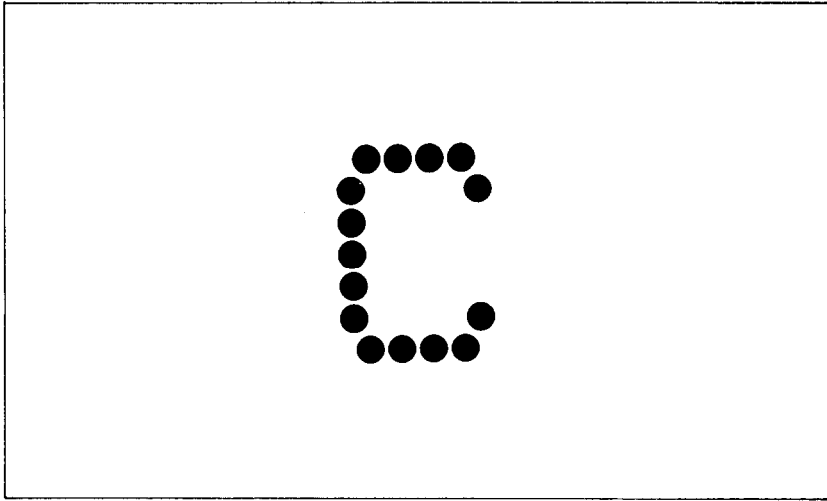

Figure 9-1. The letter "C" is created by printing 15 dots.

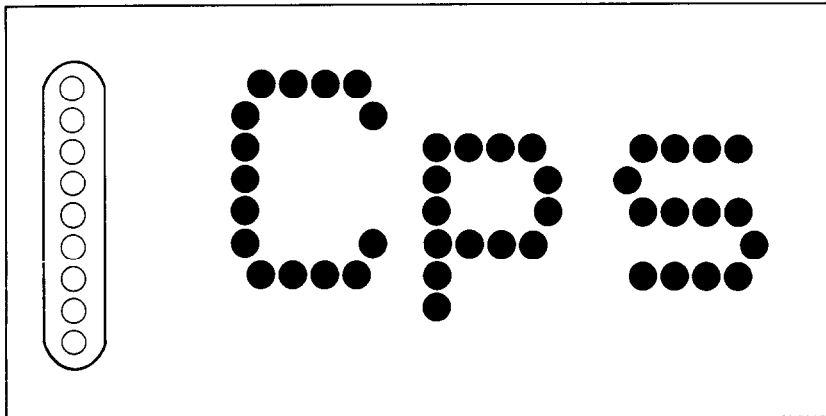

Figure 9-2. As the printhead moves across the page, each of the wires prints one row of dots.

THE PRINT MATRIX

All of the standard characters that this printer prints are formed from patterns of dots that are permanently stored in the printer's *ROM* (read-only memory). This includes all of the standard ASCII characters, the block graphics and special characters, the NLQ characters and the italic characters.

But there is another area of memory in the printer reserved for *user-defined* character. This is character that you design and *download* into this printer. When download character is defined it is stored in *RAM* (random access memory), which allows you to define or modify it at any time.

Each of these characters, whether it is from the standard character ROM or in download RAM, it is constructed on a grid which is six "boxes" wide by eight "boxes" high. The dots used to print a character can be inside any of the boxes. In addition, a dot can straddle any of vertical lines. For an example, take a look at the enlarged "9" superimposed on the grid in Figure 9-3. As you can see, some dots are inside the boxes, and some are centered on the vertical lines. This, in effect, makes the character grid 11 dots wide by 8 dots high. To see how the rest of the characters in the standard character ROM are constructed, take a look at Appendix C.

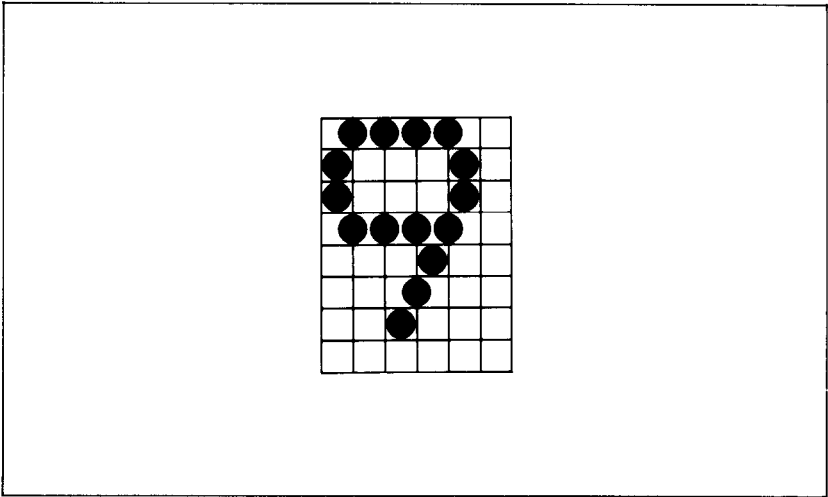

Figure 9-3. Dots can be inside boxes or straddle the vertical lines of the grid.

DEFINING YOUR OWN CHARACTER

You've seen how the engineers at Star designed their characters by using a grid to lay out the dots. Now you can define characters exactly the same way. Make up some grids (photocopy Figure 9-4 if you wish) and get ready to be creative! (Just in case you are not feeling creative, and to make our explanations a little clearer, we'll be using a picture of a chemist's flask as an example of a download character. You can see how we've laid it out in Figure 9-5.)

You'll notice that Figure 9-4 includes a lot of information around the grid. Don't be intimidated; we'll explain each time we come to it in our discussion of defining and actually printing download characters. You may have noticed that this grid is the same as the one shown in Figure 9-3. Which leads us to ...

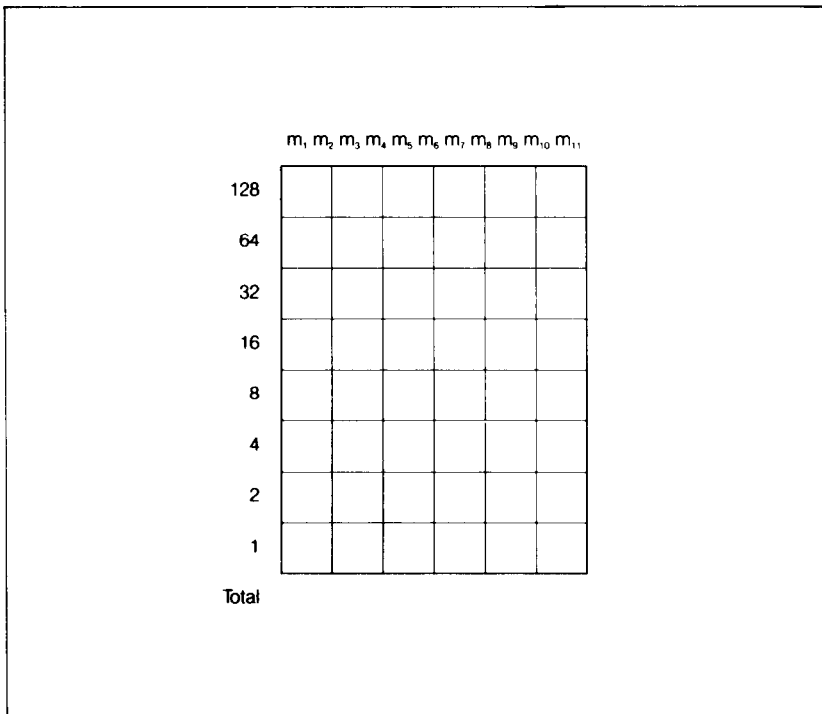

Figure 9-4. Use this grid (or similar to it) to define your own characters.

■ Rule 1: Download character is eight dots high

As you noticed in Figure 9-2, capital letters, most lowercase letters, and most special characters use only the top seven pins of the printhead. Download character can go one better: they can use as many as eight of the nine wires in the printhead. So our grid is eight dots high.

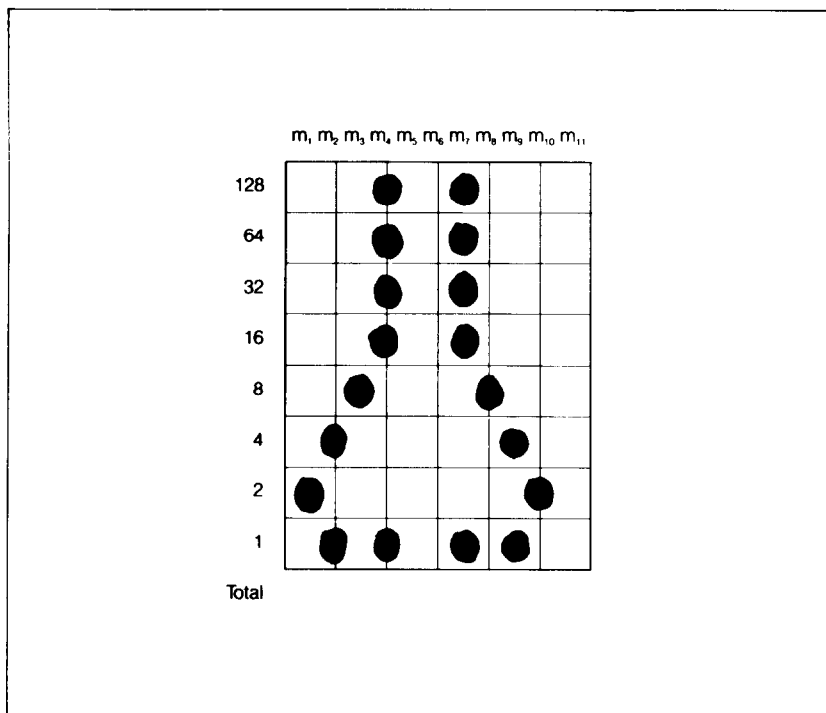

Figure 9-5. We've designed a character.

■ Rule 2: Dots cannot overlap

As you can see in Figure 9-5 our flask has a nearly continuous outline. But, you may ask, why not make it a *really* solid line and print all the intermediate dots, as shown in Figure 9-6? Because the dots that straddle the vertical lines in the grid actually overlap those inside the boxes. If we tried to print overlapping dots, the printhead of this printer would have to slow down and back up to print both dots – not very efficient! To avoid this inefficiency, this printer will not allow you to define a character like Figure 9-6. (Actually, you can define it, but when it prints,

this printer will leave out the overlapping dots, so that it would print like Figure 9-5.)

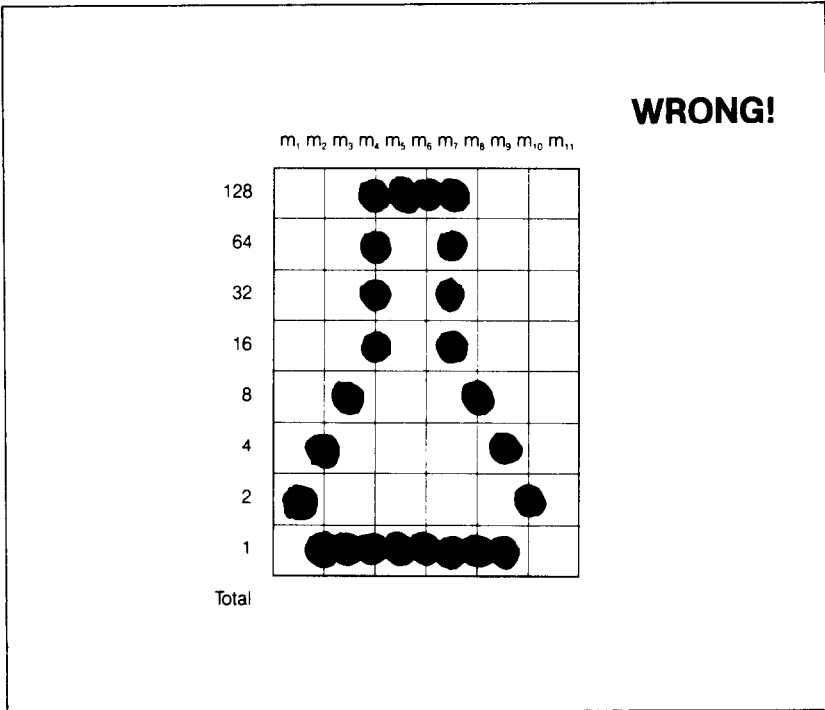

Figure 9-6. Dots cannot overlap; those in immediately adjacent “half columns” will be ignored when the character is printed.

■ Add up each column of dots

Now it's time to give our creative side a break and get down to some basic arithmetic. That's where the numbers down the left side of the grid come in. Notice that there is a number for each row of dots and that each number is twice the number below it. By making these numbers powers of two, we can take any combination of dots in a vertical column and assign them a unique value. Some examples will make this clearer. As shown in Figure 9-7, if we add the numbers for the dots that print in a column, the sum will be a number in the range of 0 to 255. Each number from 0~255 represents a unique combination of dots.

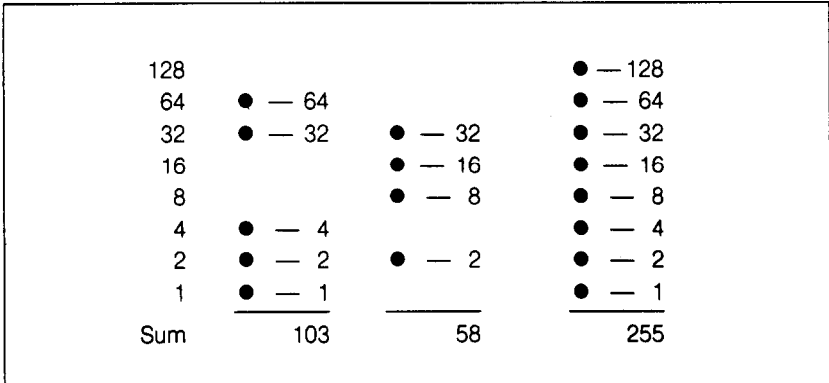

Figure 9-7. By adding the values of each dot in a column, you'll get a unique description for any combination of dots.

So add up the values of the dots in each column using this system. In Figure 9-8 we've shown our grid with the sums of the columns filled in across the bottom (see if these agree with your answers!). Across the top of the grid you've probably noticed the cryptic labeling of each column: m_1, m_2, m_3 , etc. These labels correspond to the labels in the command syntax statement, which we'll get to shortly.

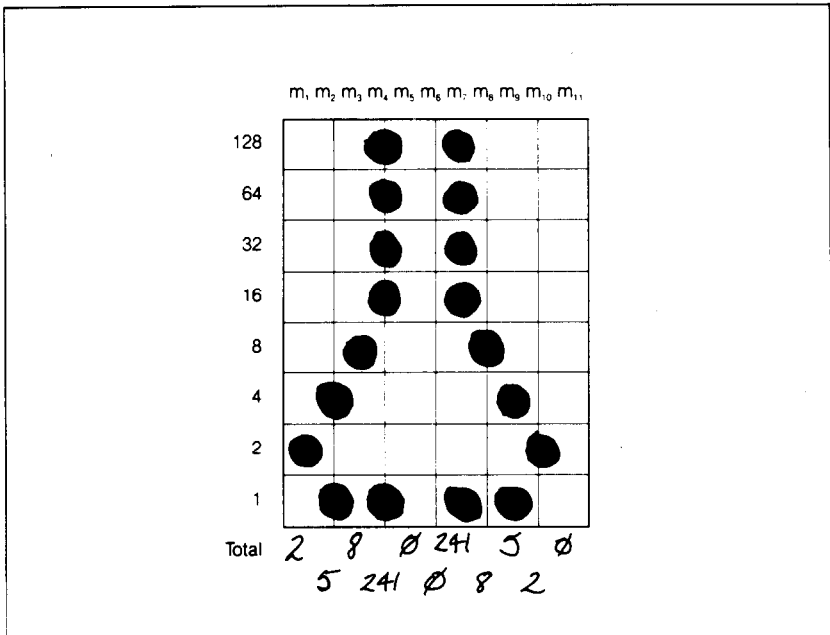

Figure 9-8. Add the values of the dots in each column and write the sum of each column at the bottom.

■ Download character definition command

You've read through a long explanation of download character and we haven't even told you the command syntax yet! Now the wait is over.

First of all, OPEN your printer following the secondary address as "5".

Then send the information of your defined character data to your printer as shown below.

```
m1 m2 ... m10 m11
```

You'll probably recognize *m1 ... m11* from the top of our layout grid. That's right, each column is described by one byte. Now we've got everything we need to download one character to the printer. Let's send the information to the printer. Enter the program and run it.

```
10 OPEN 5,4,5
20 DATA 2, 5, 8, 241, 0, 0, 241, 8, 5, 2, 0
30 FOR I=1 TO 11
40 READ A: A$=A$+CHR$(A)
50 NEXT I
60 PRINT#5, A$
70 CLOSE 5
```

When you run this program, it looks like nothing happens. That's OK. We'll see why in just a moment.

PRINTING DOWNLOAD CHARACTER

You've now defined and sent the character to the printer. But how do you know that? Try this program:

```
10 PRINT 4,4
20 PRINT#4 CHR$(254)
30 CLOSE 4
```

Voila! It should have printed out the character we defined. Your printout should look like this:

In addition to the character you have defined, your printer also prints all characters. This makes it very easy to combine user-defined character with regular text.

If this printer didn't have this feature, mixing download and standard characters would be rather inconvenient: every time you wanted to use a download character you would have to switch back and forth between character sets.

MEMO

CHAPTER 10

PRINTING WITH DOT GRAPHICS

In Chapter 9 you were introduced to a form of computer graphics; you were able to actually define characters dot by dot. In this chapter you'll learn to use the same principles to make your printer print whole pages of dot graphics! We'll show you how to use dot graphics to create "super download characters". In addition, you'll see how your printer can be used as a graphic plotter. This can have some practical business applications as well as create some terrific computer art!

COMPARING DOT GRAPHICS WITH DOWNLOAD CHARACTERS

A good understanding of dot graphics requires an understanding of how dot matrix printers work; you may want to review the first few pages of Chapter 9. The principles for dot graphics are the same as those for download characters.

There are some differences in the way they are implemented however. While download commands can be used to define a character eleven columns of dot wide, dot graphics commands can be used to define a shape as narrow as one column of dots wide or as wide as 480 dots on this printer!

There is no "descender data" with dot graphics; graphic images are always printed with the same seven pins of the print head.

So when do you use graphics and when do you use download characters? There are several instances when dot graphics are clearly the best way to approach the problem:

- If the graphic image to be printed is wider than 11 dots or higher than 8 dots.

- If an image is to be printed just one time, as opposed to a frequently used “text” character.

USING THE DOT GRAPHICS COMMAND

The command to print dot graphics uses this format:

```
CHR$(8);  m1 m2 ...
```

By using CHR\$(8) you can enter the dot graphics mode. This allows you to design and print dot graphics by inputting dot graphics data.

■ Specifying the graphics data

Now that we’ve told the printer to enter the dot graphics mode, we better figure out how to send the graphics data. Just as you do with download characters, with dot graphics you have control of the firing of every single pin on your printer’s print head. In Figure 10-1, you can see that we’ve labeled each pin on the print head with a number, as well did with download characters. (You should note one important difference: this time the *top* pin has the lowest value; for download character definitions it is the bottom pin.) And specifying to figure is done in the same way with one exception: to fire the second pin from the top, for instance, send a CHR\$(130) because the second pin value is 2 and add 128 to assign the dot graphics data. Firing se-

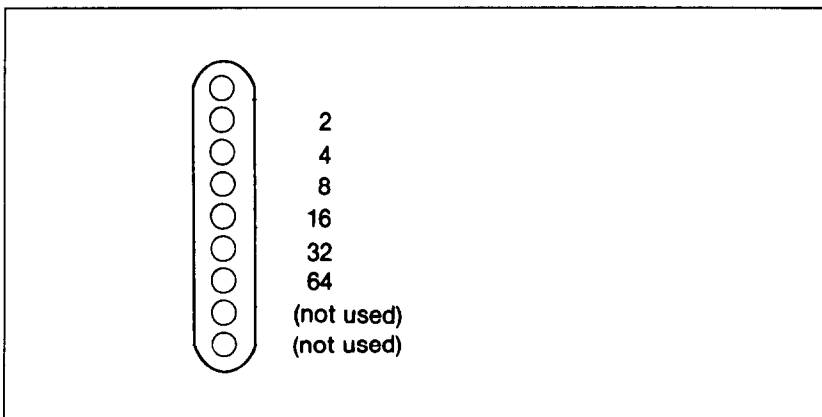

Figure 10-1. Starting with the least significant bit at the top, each pin of the print head is assigned a value which is a power of two.

veral pins at once is done in a similar fashion. For example, to print the first, third, and fourth dots, add their values and 128 ($1 + 4 + 8 + 128$) to send this total: CHR\$(141). This is one byte of graphics data; it would replace *m1* in our format statement above.

■ Combining text and graphics

It's also possible to mix text and graphics in one line. This can be useful for labeling charts or graphics, or even inserting fancy graphics in text.

PRINTING A DESIGN OR LOGO

Since you control the firing of every pin, you can print nearly anything with this printer that you can draw (and probably better, if you're like most computer users!). This can be used for creating "computer art" or drawing maps. Or, as we'll show you here, you can use dot graphics to print your logo at the top of each letter you print.

Designing an image to print with dot graphics is much like designing download characters. The best way to start is to lay out your image on graph paper. Since you can print seven rows of dots with each pass of the print head, draw a heavy horizontal line every seven rows on your graph paper. And it may be helpful to write the dot values, (192, 160, 144, etc.) down the left side of each row. Then after you've filled in the "dots" that you want to print, it's time to get out the old calculator again! Just as you did with download characters, add up the values of each column of dots and add 128 for the graphics data; this makes up one byte.

In the program below, we've taken the logo graphics information and put it into BASIC DATA statements. The program itself is short and simple.

The printout from the program is shown right below the program.

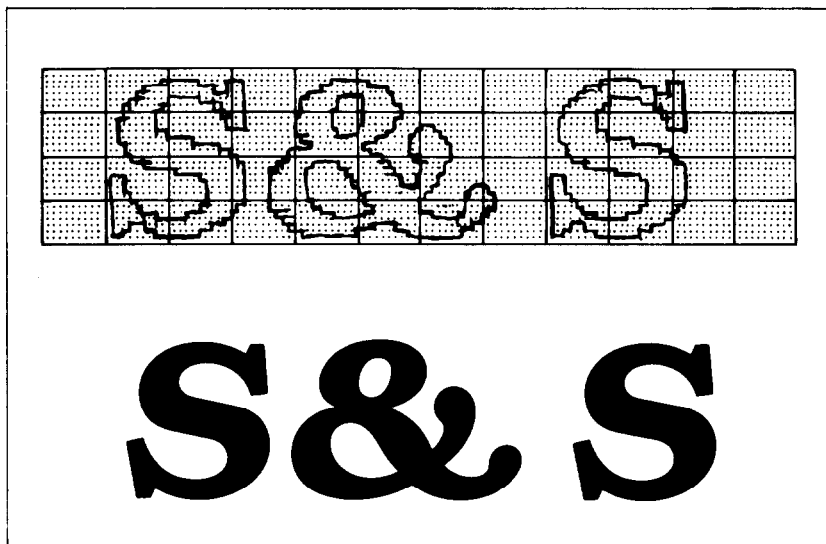

Figure 10-2. By laying out the logo on graph paper, you can calculate all of the graphics data.

```

10 OPEN 4,4
20 PRINT#4, CHR$(8);
30 FOR I=1 TO 404
40 READ A
50 PRINT#4, CHR$(A);
60 NEXT I
70 PRINT#4, CHR$(15)
80 CLOSE 4
90 REM ROW 1
100 DATA 128,128,128,192,224,240,248,248,248,188
110 DATA 156,156,156,156,156,184,184,240,240,252
120 DATA 252,252,128,128,128,128,128,128,128,128
130 DATA 128,224,240,240,248,248,252,156,156,156
140 DATA 156,252,248,248,248,240,192,128,128,128
150 DATA 128,128,128,128,128,128,128,128,128,128
160 DATA 128,128,128,128,128,128,128,128,128,128
170 DATA 128,128,128,192,224,240,248,248,248,188
180 DATA 156,156,156,156,156,184,184,240,240,252
190 DATA 252,252,128,128,128,128,128,128,128,128
200 DATA 13 : REM CARRIAGE RETURN
210 REM ROW 2
220 DATA 128,128,158,255,255,255,255,255,248,248
230 DATA 240,240,240,240,224,224,224,224,193,199

```

240 DATA 135,135,128,128,128,128,128,128,128,128,192
250 DATA 207,223,223,255,255,255,248,240,240,240
260 DATA 252,223,159,143,143,135,129,128,240,248
270 DATA 252,252,248,240,128,128,128,128,128,128
280 DATA 128,128,128,128,128,128,128,128,128,128
290 DATA 128,128,158,255,255,255,255,255,248,248
300 DATA 240,240,240,240,224,224,224,224,193,199
310 DATA 135,135,128,128,128,128,128,128,128,128
320 DATA 13 : REM CARRIAGE RETURN
330 REM ROW 3
340 DATA 128,248,248,192,129,129,131,131,131,131
350 DATA 131,135,135,135,135,143,255,255,255,255
360 DATA 255,254,128,128,128,128,252,254,255,255
370 DATA 255,255,131,129,129,129,129,131,135,143
380 DATA 191,255,255,255,254,252,248,224,224,248
390 DATA 255,191,159,135,129,128,128,192,224,224
400 DATA 224,192,128,128,128,128,128,128,128,128
410 DATA 128,248,248,192,129,129,131,131,131,131
420 DATA 131,135,135,135,135,143,255,255,255,255
430 DATA 255,254,128,128,128,128,128,128,128,128
440 DATA 13 : REM CARRIAGE RETURN
450 REM ROW 4
460 DATA 128,191,191,159,143,142,156,156,184,184
470 DATA 184,184,184,188,188,158,159,143,143,135
480 DATA 131,129,128,128,128,128,135,143,159,159
490 DATA 159,191,191,190,188,188,184,184,184,184
500 DATA 152,157,143,143,143,143,159,159,191,191
510 DATA 188,188,184,184,184,184,188,159,143,143
520 DATA 135,131,128,128,128,128,128,128,128,128
530 DATA 128,191,191,159,143,142,156,156,184,184
540 DATA 184,184,184,188,188,158,159,143,143,135
550 DATA 131,129,128,128,128,128,128,128,128,128
560 DATA 13 : REM CARRIAGE RETURN

S&S

CREATING BAR CHARTS

At the end of this chapter we'll show you a special function in the dot graphics mode.

You can create a bar chart using the repeat dot graphic function. The command to the repeat dot graphic mode is shown below:

```
CHR$(8) ..... CHR$(26);CHR$(n);CHR$(d)
```

This codes sequence specifies the repeated printing of dot graphic data. "n" is a binary number (0 through 255) which specifies the desired number of the printed repetition; followed by one-byte dot graphic data to be printing repeatedly.

When 0 is specified for "n", it is ready as 256. In order to repeat more than 256 times you need to use this code twice.

Try this program:

```
10 OPEN 4,4
20 FOR I=1 TO 6
30 READ N
40 PRINT#4, CHR$(8);CHR$(26);CHR$(N);CHR$(242);
50 PRINT#4, CHR$(15); N
60 NEXT I
70 FOR J=1 TO 8
80 PRINT#4
90 NEXT J
100 CLOSE 4
110 DATA 34, 57, 75, 89, 120, 183
```

When you run this program you will get like this:

```
===== 34
===== 57
===== 75
===== 89
===== 120
===== 183
```

CHAPTER 11

BASIC MAINTENANCE

As almost any good mechanic will tell you, dust and heat are prime enemies of any mechanism, and this printer is no exception. The best maintenance is *preventive*. So, to start with, we hope you've found a clean, dust-free location with a comfortable temperature range for both you and your computer/printer system. Chapter 1 gives you further tips on locating your printer.

CLEANING YOUR PRINTER

The second rule for long life is *periodic cleaning*. Both inside and outside of the case and covers respond gratefully to periodic cleaning with a damp rag and alcohol. Do this whenever the case appears to be getting dirty, always being careful to avoid dripping alcohol on the printer mechanism.

To remove dust and paper lint from inside the printer areas, it's best to use a soft brush, *but*, be very, very careful not to bend or injure any electronic parts or wiring, as they are vulnerable to a heavy-handed touch.

Besides the periodic cleanings, the only other maintenance you'll likely encounter will be replacing a blown fuse, or replacement of the print head after a long period of use.

REPLACING A FUSE

How can you tell when you've blown a fuse? Well, when the printer won't operate and the power lamp on the control panel isn't lit, even though you're sure that the power switch is *on* and the printer is plugged in — it's likely a blown fuse.

To check the fuse, you start by turning the power switch *off* and unplugging the power cord.

Warning: There is an extreme shock hazard inside the printer. To avoid serious injury, it is important the power cord is disconnected.

Next, remove the upper case by pulling off the platen knob.

Caution: Don't twist or turn the platen knob; pull it *straight* off.

Then remove the fastening screws along the back side. Lift the back edge of the cover and at the same time, pull it slightly forward to release the front of the case. Lift it all the way off, being careful not to pull the wires which connect the cover to the case.

When the case is off, check Figure 11-1 for location of the fuse, which you'll find held by its clamps close to the power switch.

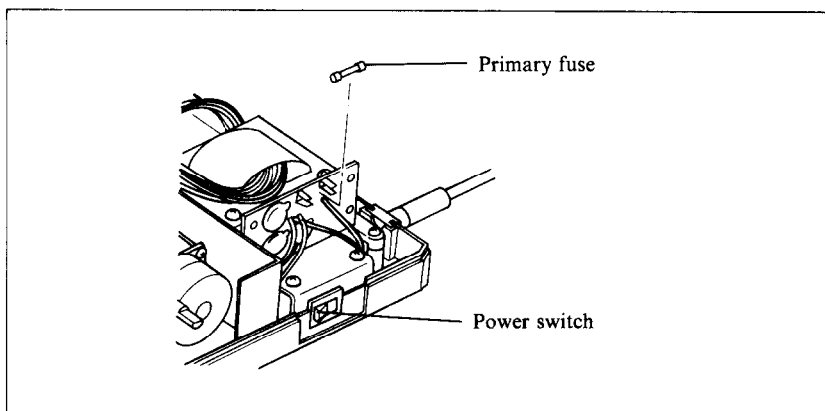

Figure 11-1. After removing the screws, pull the upper case slightly forward and lift it off the printer. The fuse is located near the power switch.

The fuse is a commonly used type, with a metal strip suspended in a glass and metal case. If the strip is broken, the fuse is blown. Replace this fuse with a 1.25A/125V slow-blow type fuse (Bell 5MT1.25 or equivalent) for 120V version, or a 630mA/250V slow-blow type fuse for 220V/240V versions. Now reassemble the printer and test-run it. If the printer still isn't working, call on your dealer/service center for help.

REPLACING THE PRINT HEAD

The dot matrix print head has a remarkably long life, printing perhaps 100,000,000 characters before it wears out. You'll know

when that happens when the printout is too faint for your taste even after replacing the ink ribbon.

Warning: The print head gets hot during operation, so let it cool off for a while, if necessary, to avoid burning your fingers.

To replace the print head, start by turning the power switch off and unplugging the power cord.

Then, in sequence:

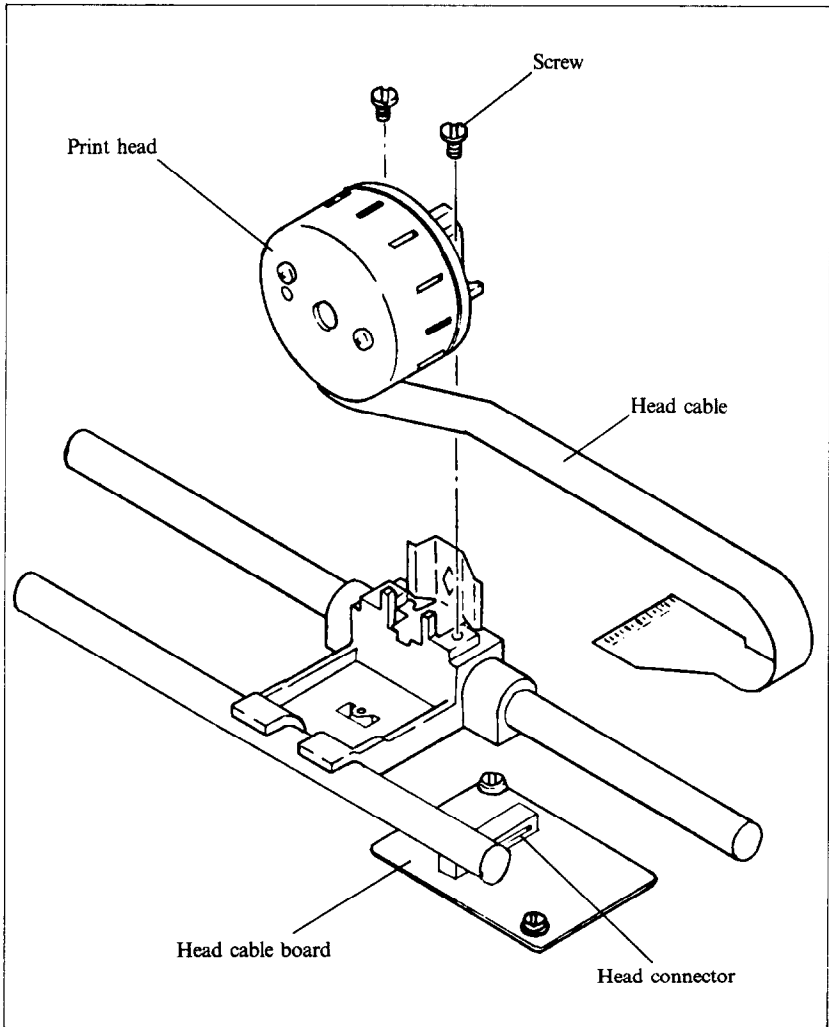

Figure 11-2. Replacement of the printer's print head is simple.

1. Remove the printer cover and the ink ribbon.
2. Remove the two screws fastening the print head.
3. While holding the print head, pull off the head cable while holding down the head cable board.
4. Insert the head cable to the head cable board and fasten with the same two screws.
5. Apply "screw lock," (an adhesive available at hardware stores) to the heads of the screws.

Be absolutely sure that you've made a good solid connection between the print head and its cable connector, or it could cause problems.

APPENDIX A

DIP SWITCH SETTINGS

The DIP (dual in-line package) switch controls some of the functions of the printer. A DIP switch actually contains several individual switches. This printer has one DIP switch with 8 individual switches in it, and one DIP switch with 4. Figure A-1 is a drawing of a typical DIP switch.

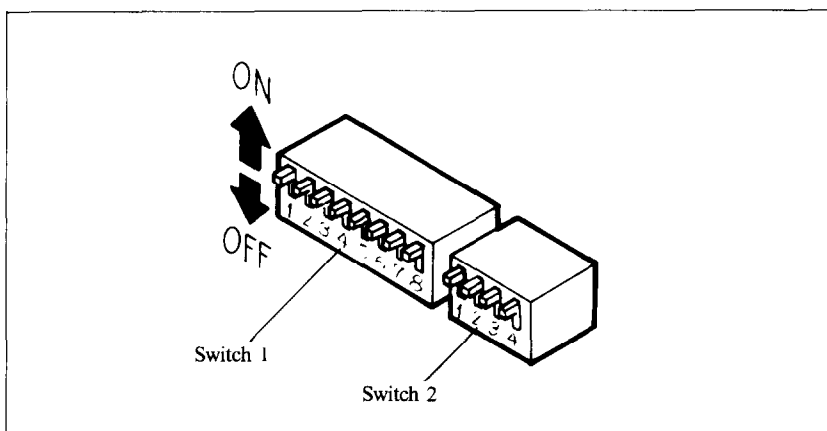

Figure A-1. A DIP switch is actually of several small switches

All two DIP switches are ready accessible from the side. They are located on the left side of the control logic board, and can be seen on the left side of the printer. To change the setting of a switch, use a ballpoint pen or a similar object. The “on” position for a switch is upwards of the printer; “off” is downwards.

Never change the settings of any of DIP switch pins when the power is on. Turn off both the printer and your computer.

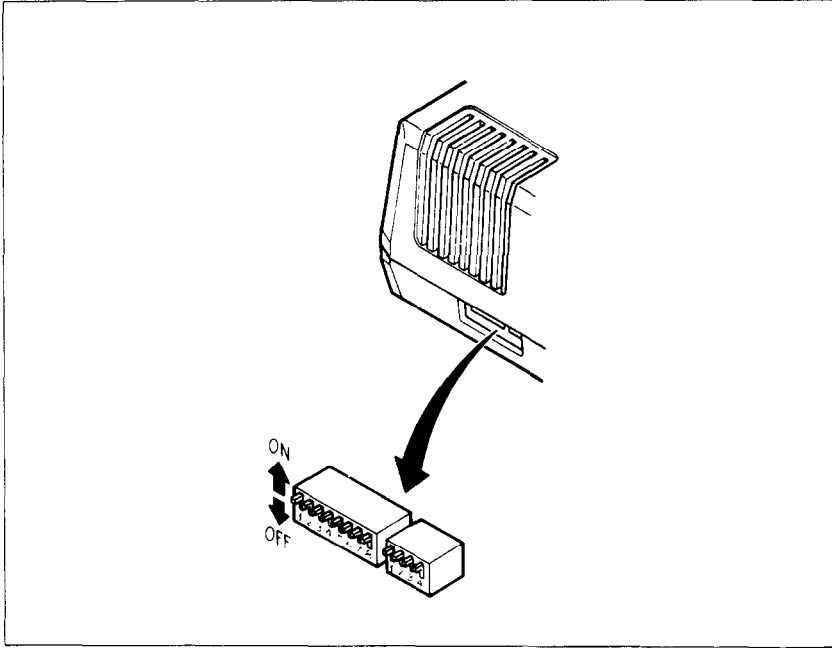

Figure A-2. The DIP switches are located on the left side of the printer.

Table A-1 summarizes the functions of the DIP switch.

Table A-1
DIP switch settings

Switch	ON	OFF
Switch 1		
1-1	11" page length	12" page length
1-2	Normal	Italic
1-3	10 CPI (pica pitch)	17 CPI (condensed pitch)
1-4	Normal	NLQ
1-5	Normal	Emphasized
1-6	1/6" paper feed	1/8" paper feed
1-7	(Not Used)	
1-8	Device number 4	Device number 5
Switch 2		
2-1	Paper-out detector on	Ignore paper out
2-2	(Not Used)	
2-3	(Not Used)	
2-4	(Not Used)	

SWITCH FUNCTIONS

Switch Function

- 1-1 Switch 1-1 sets the default page length for the printer. If switch 1-1 is ON, the page length is set to 11 inches. When switch 1-1 is OFF the page length is set to 12 inches. This switch is set ON at the factory.
- 1-2 This switch selects the default character set. If this switch is ON then the default character set is Normal characters. If this switch is OFF then the default character set is set Italic characters. This switch is set ON at the factory. This switch has no effect if the NLQ mode is selected.
- 1-3 This switch selects the default character pitch. If this switch is ON then the default pitch is 10 CPI. If this switch is OFF then the default pitch is 17 CPI. This switch is set ON at the factory. This switch has no effect if the NLQ mode is selected.
- 1-4 This switch selects the default character set. If this switch is ON then the default character set is Normal characters. If this switch is OFF then the default character set is set NLQ characters. This switch is set ON at the factory.
You can select the NLQ characters by pushing the NLQ button on the control panel.
- 1-5 This switch selects either normal or emphasized print for the default. If this switch is ON then this printer will print normal type when the power is turned on. If this switch is OFF then this printer will print emphasized type when the power is turned on. This switch is set ON at the factory.
- 1-6 This switch sets the default line spacing. When this switch is ON the default line spacing is set to 1/6 inch. This means that this printer will advance the paper 1/6 inch each time it receives a line feed. When this switch is OFF the default line spacing is 1/8 inch. This switch is set ON at the factory.
- 1-8 This switch selects the device number for this printer. When this switch is turned ON the device number is set to 4. If this switch is turned OFF the device number is set to 5. This switch is set to ON at the factory.

- 2-1 This switch disables the paper-out detector. If this switch is ON the printer will signal the computer when it runs out of paper and will stop printing. If this switch is OFF the printer will ignore the paper-out detector and will continue printing. This switch is set ON at the factory.

APPENDIX B

ASCII CODES AND CONVERSION CHART

Standard ASCII Codes			Character mode		Function
Decimal	Hexadecimal	Binary	Graphic	Business	
0	00	0000 0000			
1	01	0000 0001			
2	02	0000 0010			
3	03	0000 0011			
4	04	0000 0100			
5	05	0000 0101			
6	06	0000 0110			
7	07	0000 0111	BEL	BEL	Bell
8	08	0000 1000	BS	BS	Dot graphics on
9	09	0000 1001			
10	0A	0000 1010	LF	LF	Line feed
11	0B	0000 1011			
12	0C	0000 1100	FF	FF	Form feed
13	0D	0000 1101	CR	CR	Carriage return
14	0E	0000 1110	SO	SO	Expanded print on
15	0F	0000 1111	SI	SI	Expanded print off
16	10	0001 0000	DLE	DLE	Skip print position
17	11	0001 0001	DC1	DC1	Business characters on
18	12	0001 0010	DC2	DC2	Reverse field print on
19	13	0001 0011	DC3	DC3	Paging off
20	14	0001 0100			
21	15	0001 0101			
22	16	0001 0110			
23	17	0001 0111			
24	18	0001 1000			
25	19	0001 1001			
26	1A	0001 1010	SUB	SUB	Repeat graphics
27	1B	0001 1011	ESC	ESC	Skip print position
28	1C	0001 1100			
29	1D	0001 1101	GS	GS	Skip space
30	1E	0001 1110			
31	1F	0001 1111			
32	20	0010 0000	SP	SP	

Standard ASCII Codes			Character mode		Function
Decimal	Hexadecimal	Binary	Graphic	Business	
33	21	0010 0001	!	!	
34	22	0010 0010	"	"	
35	23	0010 0011	#	#	
36	24	0010 0100	\$	\$	
37	25	0010 0101	%	%	
38	26	0010 0110	&	&	
39	27	0010 0111	'	'	
40	28	0010 1000	((
41	29	0010 1001))	
42	2A	0010 1010	*	*	
43	2B	0010 1011	+	+	
44	2C	0010 1100	,	,	
45	2D	0010 1101	-	-	
46	2E	0010 1110	.	.	
47	2F	0010 1111	/	/	
48	30	0011 0000	0	0	
49	31	0011 0001	1	1	
50	32	0011 0010	2	2	
51	33	0011 0011	3	3	
52	34	0011 0100	4	4	
53	35	0011 0101	5	5	
54	36	0011 0110	6	6	
55	37	0011 0111	7	7	
56	38	0011 1000	8	8	
57	39	0011 1001	9	9	
58	3A	0011 1010	:	:	
59	3B	0011 1011	;	;	
60	3C	0011 1100	<	<	
61	3D	0011 1101	=	=	
62	3E	0011 1110	>	>	
63	3F	0011 1111	?	?	
64	40	0100 0000	@	@	
65	41	0100 0001	A	a	
66	42	0100 0010	B	b	
67	43	0100 0011	C	c	
68	44	0100 0100	D	d	
69	45	0100 0101	E	e	
70	46	0100 0110	F	f	
71	47	0100 0111	G	g	
72	48	0100 1000	H	h	
73	49	0100 1001	I	i	
74	4A	0100 1010	J	j	
75	4B	0100 1011	K	k	
76	4C	0100 1100	L	l	

Standard ASCII Codes			Character mode		Function
Decimal	Hexadecimal	Binary	Graphic	Business	
77	4D	0100 1101	M	m	
78	4E	0100 1110	N	n	
79	4F	0100 1111	O	o	
80	50	0101 0000	P	p	
81	51	0101 0001	Q	q	
82	52	0101 0010	R	r	
83	53	0101 0011	S	s	
84	54	0101 0100	T	t	
85	55	0101 0101	U	u	
86	56	0101 0110	V	v	
87	57	0101 0111	W	w	
88	58	0101 1000	X	x	
89	59	0101 1001	Y	y	
90	5A	0101 1010	Z	z	
91	5B	0101 1011	[[
92	5C	0101 1100]]	
93	5D	0101 1101	^	^	
94	5E	0101 1110	_	_	
95	5F	0101 1111	~	~	
96	60	0110 0000			
97	61	0110 0001	!	A	
98	62	0110 0010	"	B	
99	63	0110 0011	£	C	
100	64	0110 0100	\$	D	
101	65	0110 0101	%	E	
102	66	0110 0110	&	F	
103	67	0110 0111	'	G	
104	68	0110 1000	(H	
105	69	0110 1001)	I	
106	6A	0110 1010	*	J	
107	6B	0110 1011	+	K	
108	6C	0110 1100	,	L	
109	6D	0110 1101	-	M	
110	6E	0110 1110	.	N	
111	6F	0110 1111	/	O	
112	70	0111 0000	0	P	
113	71	0111 0001	1	Q	
114	72	0111 0010	2	R	
115	73	0111 0011	3	S	
116	74	0111 0100	4	T	
117	75	0111 0101	5	U	
118	76	0111 0110	6	V	
119	77	0111 0111	7	W	
120	78	0111 1000	8	X	

Standard ASCII Codes			Character mode		Function
Decimal	Hexadecimal	Binary	Graphic	Business	
121	79	0111 1001		Y	
122	7A	0111 1010	◆	Z	
123	7B	0111 1011	+	+	
124	7C	0111 1100	⌘	⌘	
125	7D	0111 1101			
126	7E	0111 1110	π	⊠	
127	7F	0111 1111	▲	⌘	
128	80	1000 0000			
129	81	1000 0001			
130	82	1000 0010			
131	83	1000 0011			
132	84	1000 0100			
133	85	1000 0101			
134	86	1000 0110			
135	87	1000 0111			
136	88	1000 1000			
137	89	1000 1001			
138	8A	1000 1010			
139	8B	1000 1011			
140	8C	1000 1100			
141	8D	1000 1101	CR	CR	Carriage return without line feed
142	8E	1000 1110			
143	8F	1000 1111			
144	90	1001 0000			
145	91	1001 0001	DC1	DC1	Graphic characters on
146	92	1001 0010	DC2	DC2	Reverse field print off
147	93	1001 0011	DC3	DC3	Paging on
148	94	1001 0100			
149	95	1001 0101			
150	96	1001 0110			
151	97	1001 0111			
152	98	1001 1000			
153	99	1001 1001			
154	9A	1001 1010			
155	9B	1001 1011			
156	9C	1001 1100			
157	9D	1001 1101			
158	9E	1001 1110			
159	9F	1001 1111			
160	A0	1010 0000			
161	A1	1010 0001	▬	▬	
162	A2	1010 0010	▬	▬	
163	A3	1010 0011	▬	▬	

Standard ASCII Codes			Character mode		Function
Decimal	Hexadecimal	Binary	Graphic	Business	
164	A4	1010 0100	—	—	
165	A5	1010 0101			
166	A6	1010 0110	⊞	⊞	
167	A7	1010 0111			
168	A8	1010 1000	⊞	⊞	
169	A9	1010 1001	▾	⊞	
170	AA	1010 1010			
171	AB	1010 1011	┆	┆	
172	AC	1010 1100	■	■	
173	AD	1010 1101	└	└	
174	AE	1010 1110	┐	┐	
175	AF	1010 1111	—	—	
176	B0	1011 0000	┐	┐	
177	B1	1011 0001	└	└	
178	B2	1011 0010	┐	┐	
179	B3	1011 0011	└	└	
180	B4	1011 0100			
181	B5	1011 0101			
182	B6	1011 0110			
183	B7	1011 0111	—	—	
184	B8	1011 1000	—	—	
185	B9	1011 1001	—	—	
186	BA	1011 1010	└	└	
187	BB	1011 1011	┐	┐	
188	BC	1011 1100	■	■	
189	BD	1011 1101	└	└	
190	BE	1011 1110	┐	┐	
191	BF	1011 1111	■	■	
192	C0	1100 0000	—	—	
193	C1	1100 0001	♣	A	
194	C2	1100 0010		B	
195	C3	1100 0011	—	C	
196	C4	1100 0100	—	D	
197	C5	1100 0101	—	E	
198	C6	1100 0110	—	F	
199	C7	1100 0111		G	
200	C8	1100 1000		H	
201	C9	1100 1001	┐	I	
202	CA	1100 1010	└	J	
203	CB	1100 1011	┐	K	
204	CC	1100 1100	└	L	
205	CD	1100 1101	┐	M	
206	CE	1100 1110	└	N	
207	CF	1100 1111	┐	O	

Standard ASCII Codes			Character mode		Function
Decimal	Hexadecimal	Binary	Graphic	Business	
208	D0	1101 0000	┘	P	
209	D1	1101 0001	●	Q	
210	D2	1101 0010	├	R	
211	D3	1101 0011	◆	S	
212	D4	1101 0100	├	T	
213	D5	1101 0101	┘	U	
214	D6	1101 0110	X	V	
215	D7	1101 0111	○	W	
216	D8	1101 1000	⊕	X	
217	D9	1101 1001	├	Y	
218	DA	1101 1010	◆	Z	
219	DB	1101 1011	+	+	
220	DC	1101 1100	⊗	⊗	
221	DD	1101 1101	├	├	
222	DE	1101 1110	⌞	⊗	
223	DF	1101 1111	⌞	⊗	
224	E0	1110 0000			
225	E1	1110 0001	■	■	
226	E2	1110 0010	■	■	
227	E3	1110 0011	■	■	
228	E4	1110 0100			
229	E5	1110 0101	├	├	
230	E6	1110 0110	⊗	⊗	
231	E7	1110 0111	├	├	
232	E8	1110 1000	⊗	⊗	
233	E9	1110 1001	⌞	⊗	
234	EA	1110 1010	├	├	
235	EB	1110 1011	┘	┘	
236	EC	1110 1100	■	■	
237	ED	1110 1101	┘	┘	
238	EE	1110 1110	┘	┘	
239	EF	1110 1111	┘	┘	
240	F0	1111 0000	┘	┘	
241	F1	1111 0001	┘	┘	
242	F2	1111 0010	┘	┘	
243	F3	1111 0011	┘	┘	
244	F4	1111 0100	├	├	
245	F4	1111 0101	├	├	
246	F6	1111 0110	├	├	
247	F7	1111 0111	├	├	
248	F8	1111 1000	■	■	
249	F9	1111 1001	■	■	
250	FA	1111 1010	┘	┘	
251	FB	1111 1011	■	■	

Standard ASCII Codes			Character mode		Function
Decimal	Hexadecimal	Binary	Graphic	Business	
252	FC	1111 1100	■	■	
253	FD	1111 1101	┘	┘	
254	FE	1111 1110	■	■	
255	FF	1111 1111	▣	▣	

MEMO

APPENDIX C

CHARACTER STYLE CHARTS

■ Graphics mode

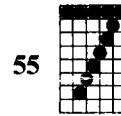
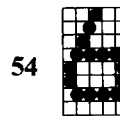
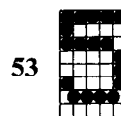
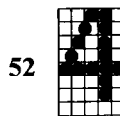
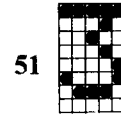
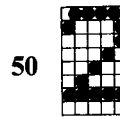
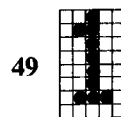
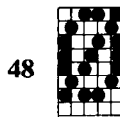
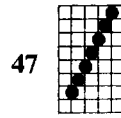
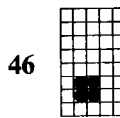
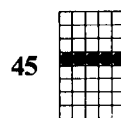
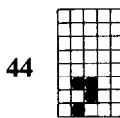
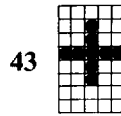
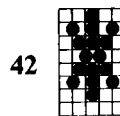
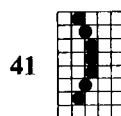
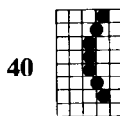
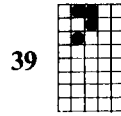
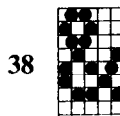
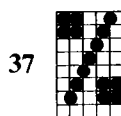
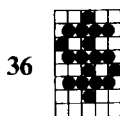
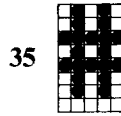
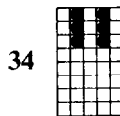
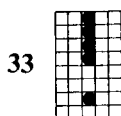
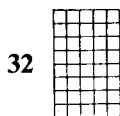

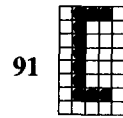
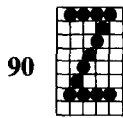
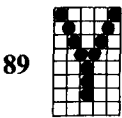
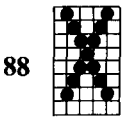
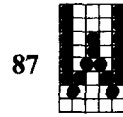
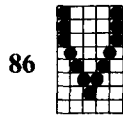
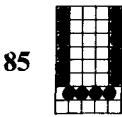
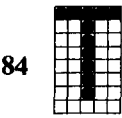
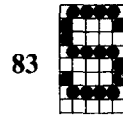
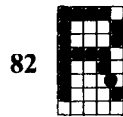
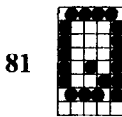
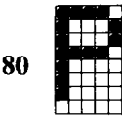
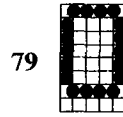
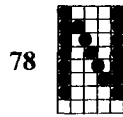
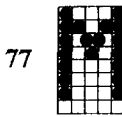
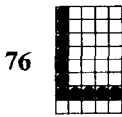
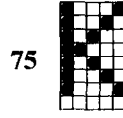
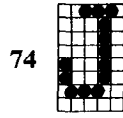
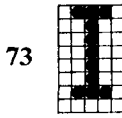
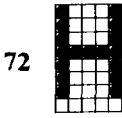
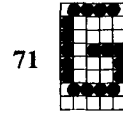
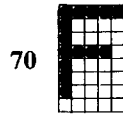
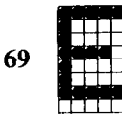
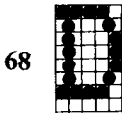
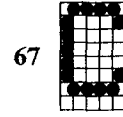
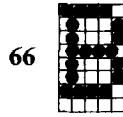
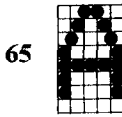
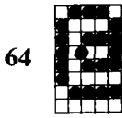
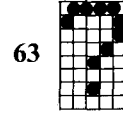
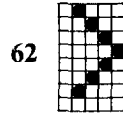
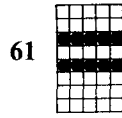
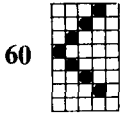
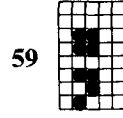
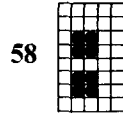
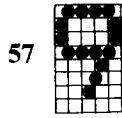
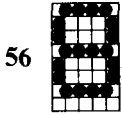

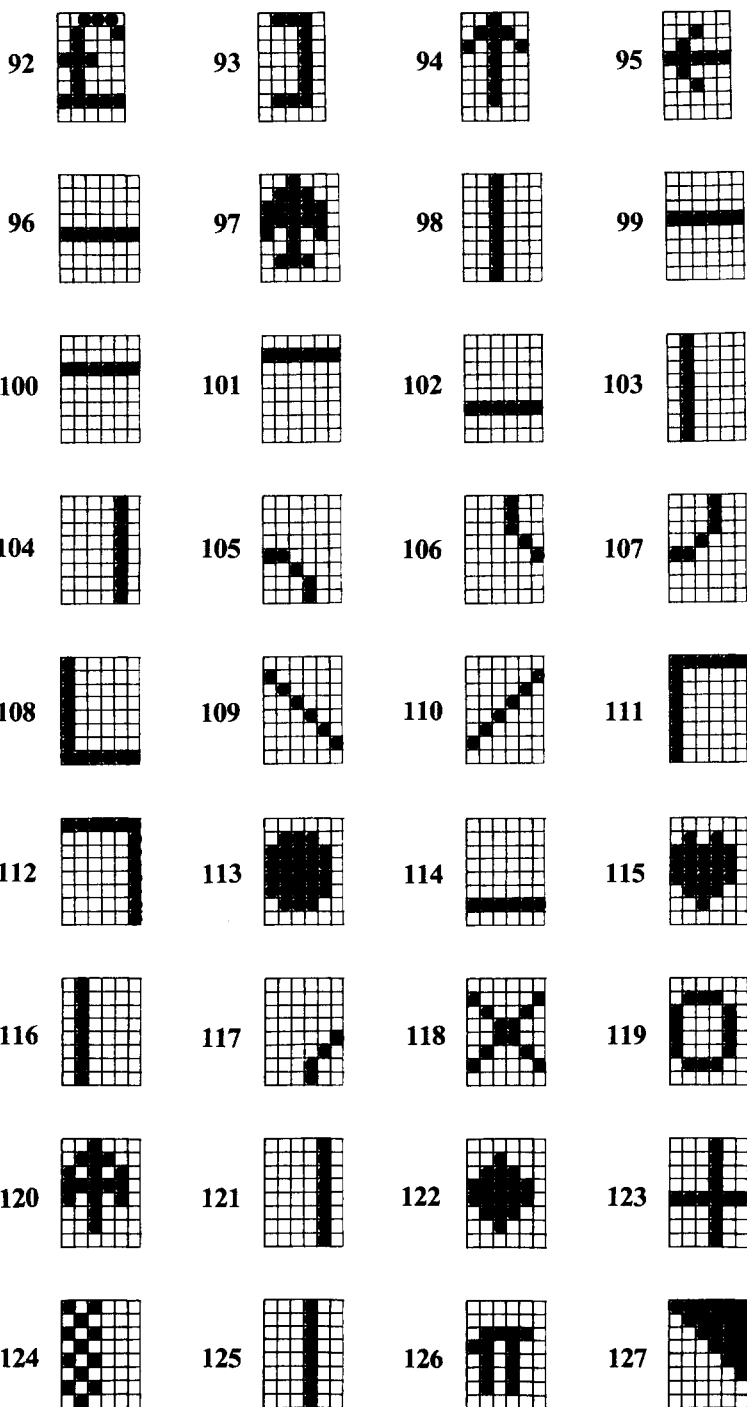

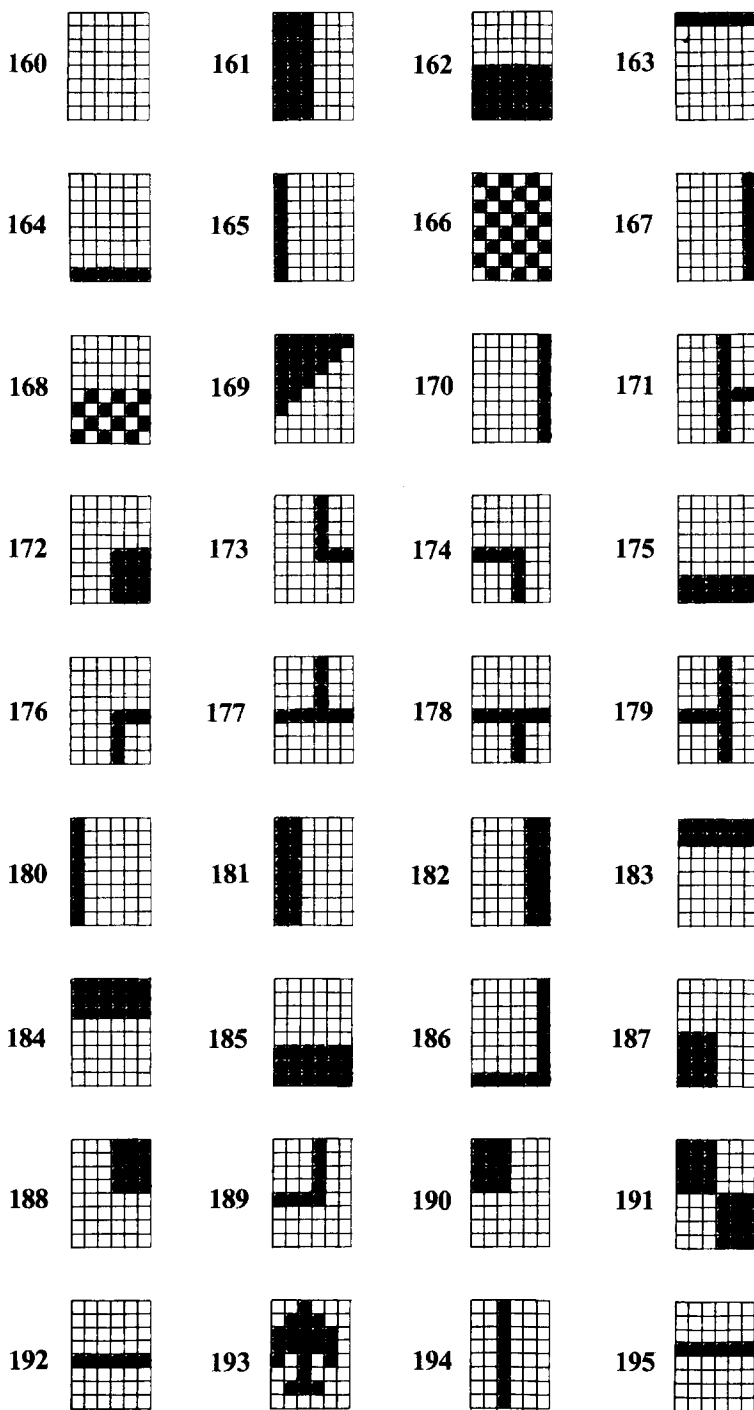

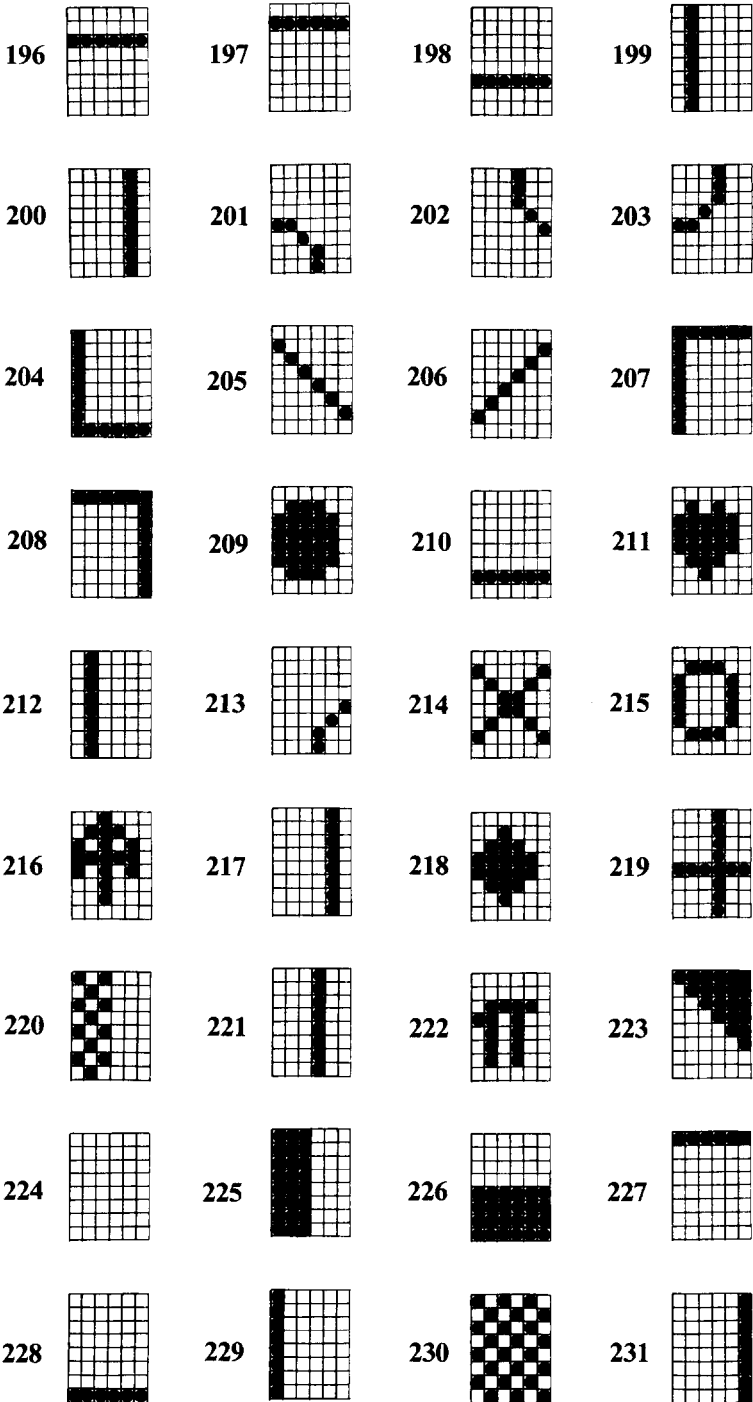

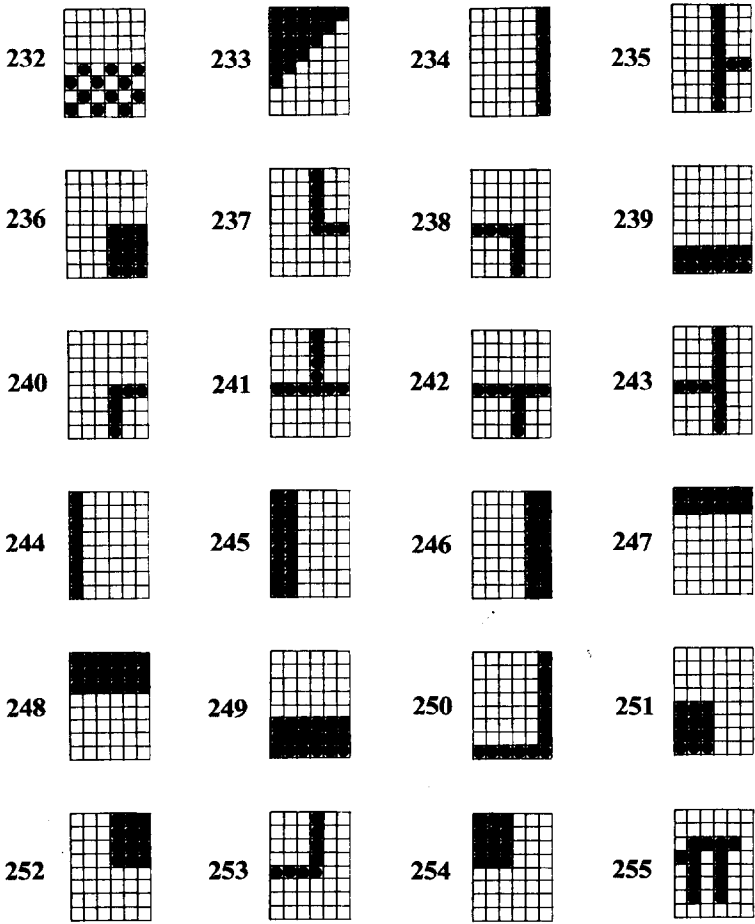

■ Business mode

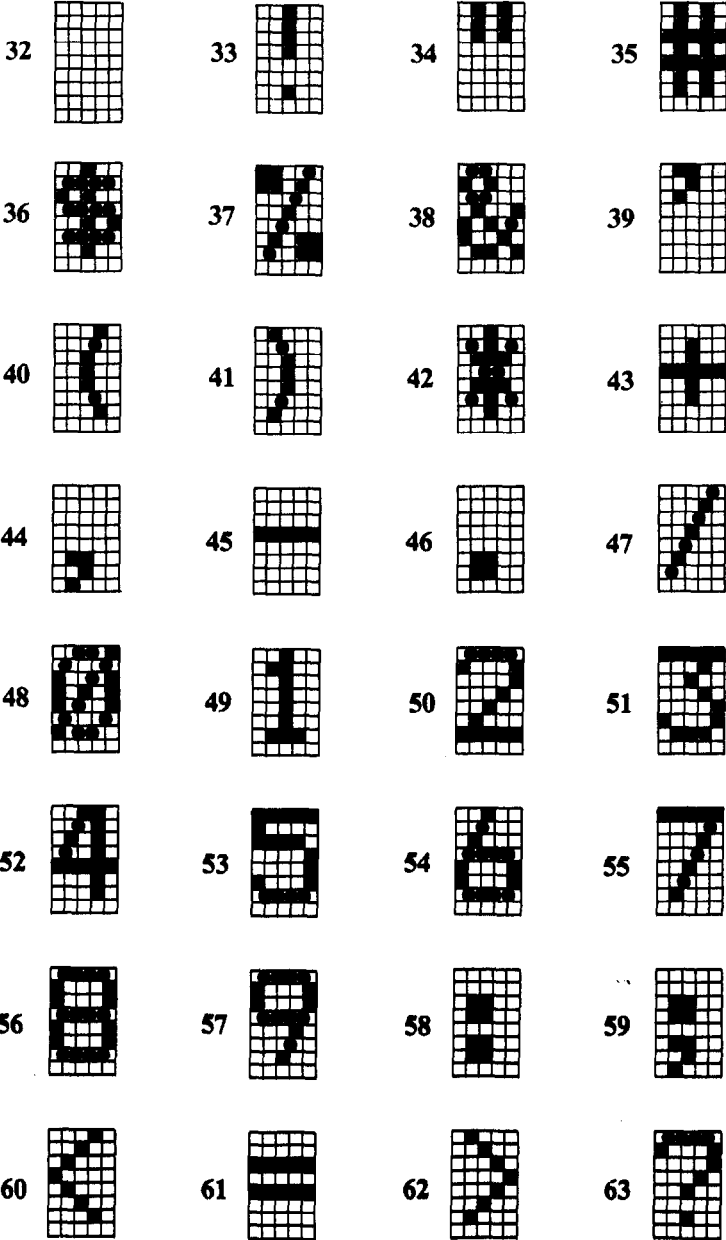

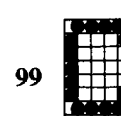
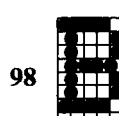
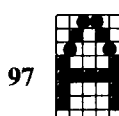
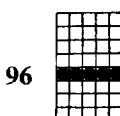
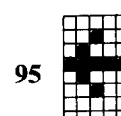
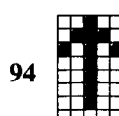
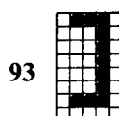
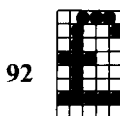
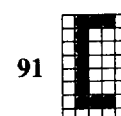
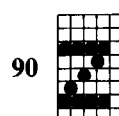
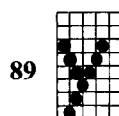
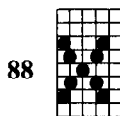
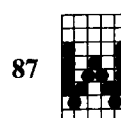
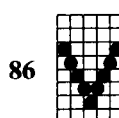
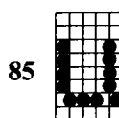
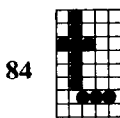
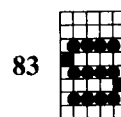
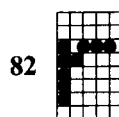
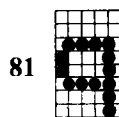
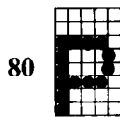
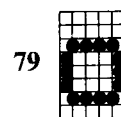
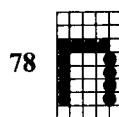
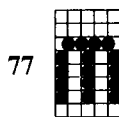
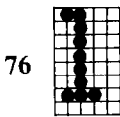
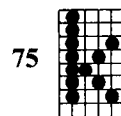
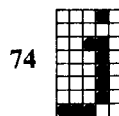
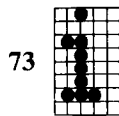
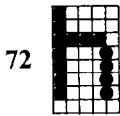
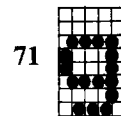
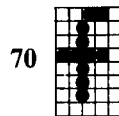
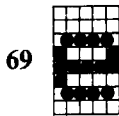
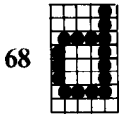
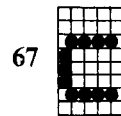
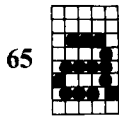
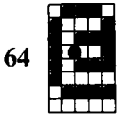

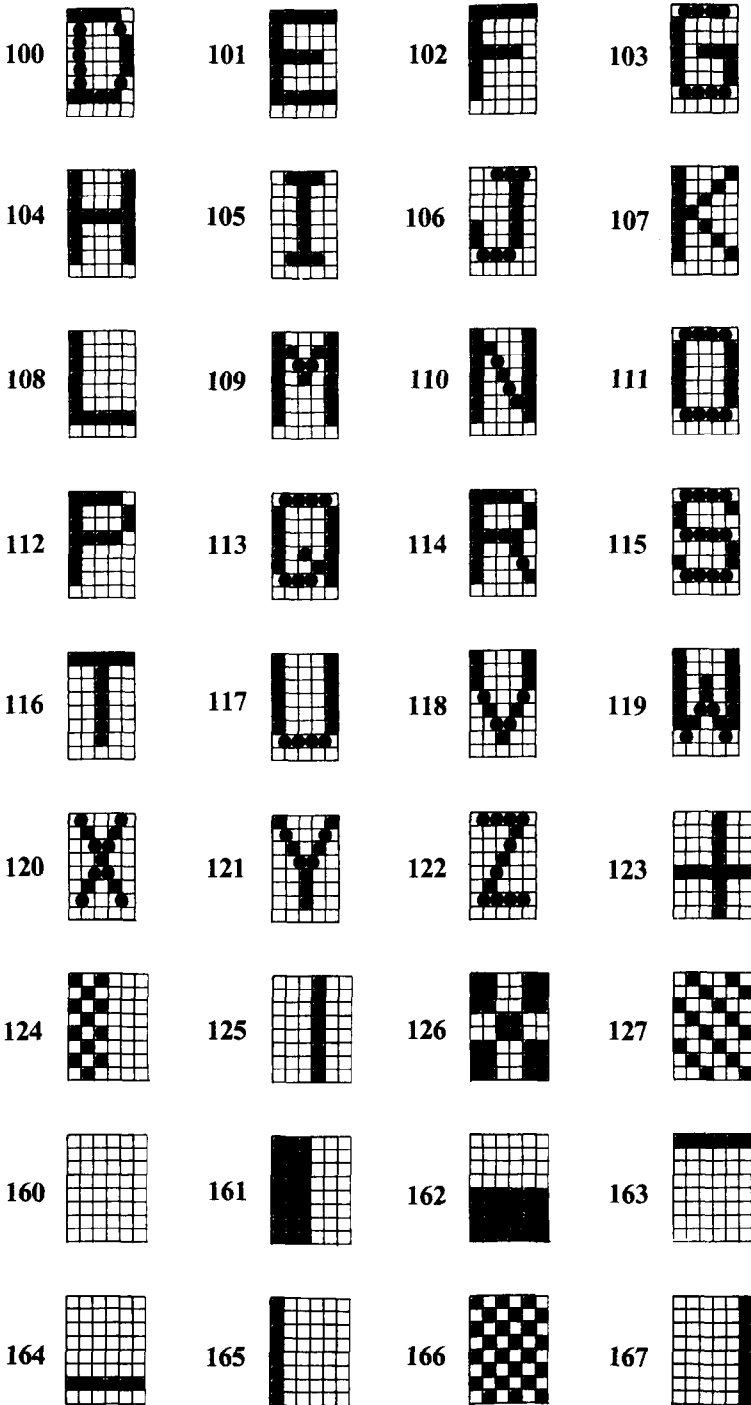

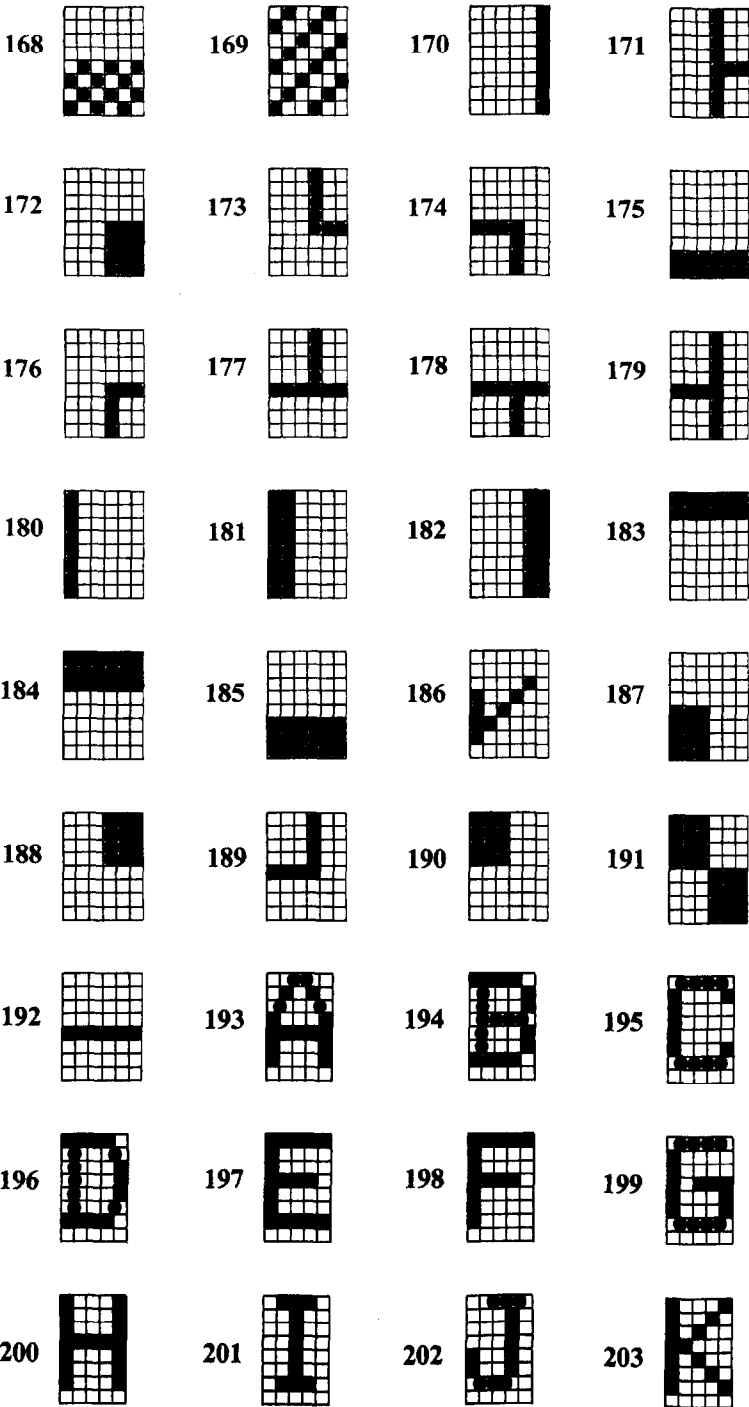

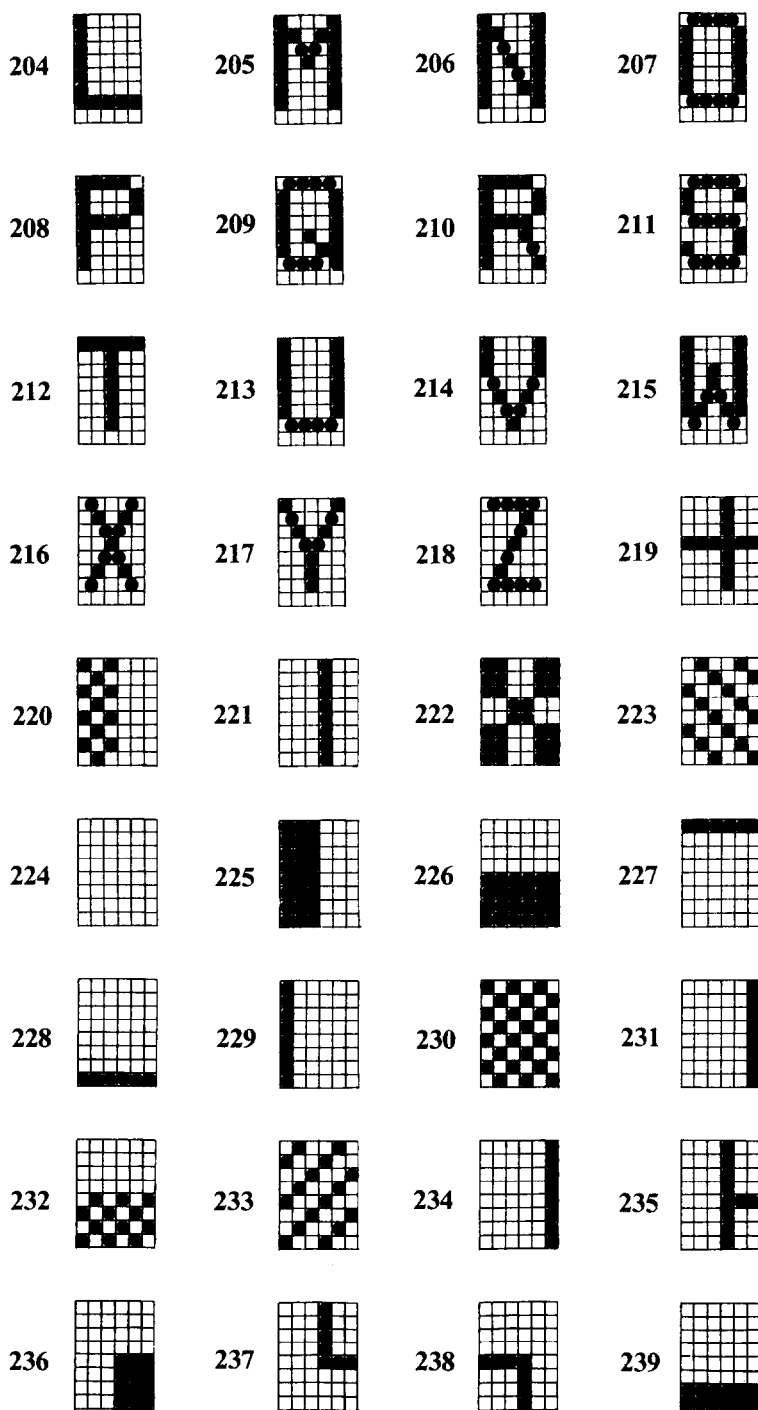

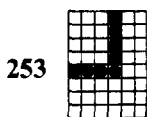
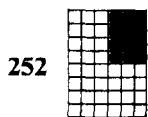
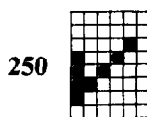
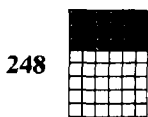
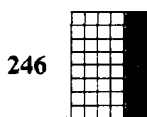
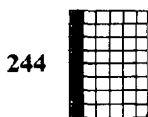
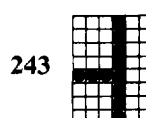
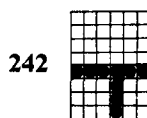
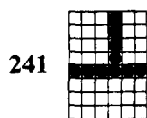
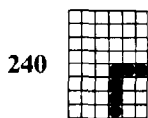

APPENDIX D

FUNCTION CODE REFERENCE

The purpose of this Appendix is to provide a quick reference for the various functions available on this printer. The descriptions of the codes appear in the following format.

PURPOSE:	Tells what the function code does.
CODE:	Control code mnemonic
(decimal ASCII)	ASCII decimal equivalent
(hex ASCII)	Hexadecimal equivalent
REMARKS:	Details how the command is used.
REFERENCE:	Tells which chapter of the manual describes the command in greater detail.

There are several commands that require that you specify a value (or values) to this printer. In these cases, we have used an italic "*n*" or "*m*" to indicate a variable. You should insert the ASCII code for proper value here.

COMMANDS TO CONTROL PRINT STYLE

These commands are used to control the font style, and special effects.

PURPOSE:	Select the graphic character mode.
CODE:	< DC1 >
(decimal ASCII)	145
(hex ASCII)	91
REMARKS:	This command selects the graphic character mode.
REFERENCE:	Chapter 8

- PURPOSE:** **Select the business character mode.**
- CODE:** < DC1 >
(decimal ASCII) 17
(hex ASCII) 11
- REMARKS:** This command selects the business character mode.
- REFERENCE:** Chapter 8
-
- PURPOSE:** **Set the printer to expanded print.**
- CODE:** < SO >
(decimal ASCII) 14
(hex ASCII) 0E
- REMARKS:** This command causes all subsequent printing except NLQ characters to be in expanded type.
- REFERENCE:** Chapter 5
-
- PURPOSE:** **Cancels expanded print.**
- CODE:** < SI >
(decimal ASCII) 15
(hex ASCII) 0F
- REMARKS:** This command resets the print size to whatever it was before being set to expanded print.
- REFERENCE:** Chapter 5

PURPOSE: Set the printer to reverse field print.

CODE: < DC2 >
(decimal ASCII) 18
(hex ASCII) 12

REMARKS: This command causes all subsequent printing to be in reverse field printing mode. This mode prints the white letters on black background.

NOTE: Do not use this mode of printing for more than five consecutive lines since extended printing in this mode will damage the print head.

REFERENCE: Chapter 5

PURPOSE: Cancels reverse field mode.

CODE: < DC2 >
(decimal ASCII) 146
(hex ASCII) 92

REMARKS: This command resets the print mode to whatever it was before being set to reverse field print.

REFERENCE: Chapter 5

COMMANDS TO CONTROL VERTICAL POSITION OF PRINT HEAD

These commands are used to move the paper relative to the location of the print head. By moving the paper up, the print head, in effect, moves down the page.

PURPOSE: Advance the paper one line (Line Feed).

CODE: < LF >
(decimal ASCII) 10
(hex ASCII) 0A

REMARKS: The actual distance advanced by the line feed is set through various codes which can be sent by the secondary address assignment of 6 (see Appendix E).

REFERENCE: Chapter 6

PURPOSE: Advance the paper to top of the next page (Form Feed).

CODE: < FF >
(decimal ASCII) 12
(hex ASCII) 0C

REMARKS: The actual length of a page by a form feed is set either by the setting of DIP switch 1-1 or through various codes by the secondary address assignment of 3 (see Appendix E).

REFERENCE: Chapter 7

- PURPOSE:** Set skip-over perforation.
- CODE:** < DC3 >
(decimal ASCII) 147
(hex ASCII) 93
- REMARKS:** This command sets the margins at the top and the bottom of the page to 3 lines each. The printer will automatically execute a form feed when the number of lines left on a page is equal to 3.
- REFERENCE:** Chapter 7
- PURPOSE:** Cancel skip-over perforation.
- CODE:** < DC3 >
(decimal ASCII) 19
(hex ASCII) 13
- REMARKS:** This command cancels both the top and the bottom margins.
- REFERENCE:** Chapter 7

COMMANDS TO CONTROL HORIZONTAL POSITIONS OF PRINT HEAD

- PURPOSE:** Return print head to home position (Carriage Return).
- CODE:** < CR >
(decimal ASCII) 13
(hex ASCII) 0D
- REMARKS:** This command returns the print head to the home positions. This command will also cause a line feed character to be generated after the carriage return, thereby advancing to the beginning of the next print line automatically.
- REFERENCE:** Chapter 6

PURPOSE: Return print head to home position without line feed.

CODE: < CR >
 (decimal ASCII) 141
 (hex ASCII) 8D

REMARKS: This command returns the print head to the home position without line feed character.

REFERENCE: Chapter 6

PURPOSE: Skip print position.

CODE: < DLE > *n1 n2*
 (decimal ASCII) 16 *n1 n2*
 (hex ASCII) 10 *n1 n2*

REMARKS: This command determines the print start position from the home position. *n1* and *n2* should be between "0" (decimal code 48, hexadecimal code 30) to "9" (decimal code 57, hexadecimal code 39).

REFERENCE: Chapter 6

PURPOSE: Skip print position in dot units.

CODE: < ESC > < DLE > *n1 n2*
 (decimal ASCII) 27 16 *n1 n2*
 (hex ASCII) 1B 10 *n1 n2*

REMARKS: This command determines the print start position from the home position in dot units. The range is from 0 to 479 using *n1* and *n2*.

PURPOSE:	Skip space.
CODE:	< GS >
(decimal ASCII)	29
(hex ASCII)	1D
REMARKS:	This command causes the printer to skip the print positions according to previously defined format. This command can be used under the secondary address assignment of "1".
REFERENCE:	Chapter 7

COMMANDS TO CONTROL DOT GRAPHICS

PURPOSE:	Enter dot graphics mode.
CODE:	< BS > <i>n1 n2 ...</i>
(decimal ASCII)	8 <i>n1 n2 ...</i>
(hex ASCII)	08 <i>n1 n2 ...</i>
REMARKS:	This command selects the dot graphics mode. The ASCII value of graphic data byte (<i>n1</i> , <i>n2</i> , etc.) determine which pins are fired for each character. This command also sets the line spacing to 7/72 inches.
REFERENCE:	Chapter 10
PURPOSE:	Repeat graphic data.
CODE:	< SUB > <i>n m</i>
(decimal ASCII)	26 <i>n m</i>
(hex ASCII)	1A <i>n m</i>
REMARKS:	This command repeats the selected graphic data (<i>m</i>) for <i>n</i> times while in the dot graphics mode.
REFERENCE:	Chapter 10

OTHER COMMANDS

PURPOSE: **Sound printer bell.**

CODE: **< BEL >**
(decimal ASCII) **7**
(hex ASCII) **07**

REMARKS: This command causes the printer tone to sound for approximately one-fourth second.

REFERENCE: Chapter 8

APPENDIX E

SECONDARY ADDRESS REFERENCE

The purpose of this Appendix is to provide a quick reference for the various assignments of the secondary addresses in the "OPEN" statement.

PURPOSE: Print data exactly as received in Graphic mode.

SECONDARY ADDRESS: 0

REMARKS: This secondary address is the default value. Whether or not you include it in your OPEN statement, the printer prints data exactly as received.

REFERENCE: Chapter 8

PURPOSE: Printing data according to a previously defined format.

SECONDARY ADDRESS: 1

REMARKS: A secondary address of 1 invokes the formatting features of your printer. The data to be printed is arrayed according to a previously specified format using the secondary address of 2.

REFERENCE: Chapter 7

PURPOSE: Storing the formatting data.

SECONDARY ADDRESS: 2

REMARKS: This secondary address determines the formatting features of your printer.

REFERENCE: Chapter 7

PURPOSE: **Setting the number of lines per page.**
SECONDARY ADDRESS: 3
REMARKS: This secondary address allows you to vary
the number of printed lines per page.
REFERENCE: Chapter 7

PURPOSE: **Enable the printer error messages.**
SECONDARY ADDRESS: 4
REMARKS: When this secondary address is transmitted,
the printer's error messages appear whenever
an error occurs.
REFERENCE: Chapter 7

PURPOSE: **Defining a download character.**
SECONDARY ADDRESS: 5
REMARKS: This secondary address allows you to define
a download character.
REFERENCE: Chapter 9

PURPOSE: **Setting the line spacing.**
SECONDARY ADDRESS: 6
REMARKS: This secondary address controls the value of
line spacing.
REFERENCE: Chapter 7

PURPOSE: **Select the business characters.**
SECONDARY ADDRESS: 7
REMARKS: This secondary address is used to print as
exactly received. It is similar to the second-
ary address "0" except that all unshifted
characters are printed in lower case and all
shifted (or capital) characters are printed in
upper case.
REFERENCE: Chapter 8

PURPOSE: **Cancel the printer error messages.**
SECONDARY ADDRESS: 9
REMARKS: This secondary address turns off the
printer's error messages selected by the sec-
ondary address "4".
REFERENCE: Chapter 8

PURPOSE: **Reset the printer.**
SECONDARY ADDRESS: 10
REMARKS: This secondary address initializes the printer
 as the power-on default.
REFERENCE: Chapter 8

MEMO

APPENDIX F

TECHNICAL SPECIFICATIONS

Printing method	Serial impact dot matrix
Printing speed	120 characters per second in draft 10 CPI
Print buffer	2K bytes
Paper feed	12 lines/second (at 1/6 inch line spacing) Sprocket and Friction feed
Printing direction	Bidirectional, logic seeking Unidirectional in dot graphics and NLQ modes
Character set	Near Letter Quality (NLQ) characters Upper/lower case characters, numerals, and symbols Italic characters Upper/lower case characters, numerals, and symbols Draft characters Upper/lower case characters, numerals, symbols, and block graphics
Character matrix	NLQ characters: 17 dot × 11 dot Standard characters: 8 dot × 11 dot Block graphics: 8 dot × 6 dot User defined: 8 dot × 11 dot Dot graphic mode: 7 dot × 480 dot
Line spacing	1/6, 1/8 inch or 7/72 inch standard <i>n</i> /216 inch programmable
Column width	
Pica	80 columns per line
Condensed	136 columns per line
Paper type	
Single-sheets	5.5 – 8.5 inches wide
Continuous paper	4 – 10 inches wide
Number of copies	Original + 2 copies
Ribbon	Star Micronics P/M SF-02B, or Under- wood 1/2 inch × 2 inch spools

Dimensions	392 (W) × 315 (D) × 145 (H) mm 15.2 (W) × 12.4 (D) × 5.7 (H) inches
Weight	7 kg (15.4 lb.)
Special features	Near Letter Quality printing Short form tear-off Easy access format switches Self-test Downloadable character Skip over perforation