

OUTLINE OF CONTENTS:

1. Brief Description
2. Power Supply
3. General Mechanical Configuration
4. Use With GEORAM
5. Use With Commodore 1700, 1764 or 1750 REU
6. Optional Modification to Turbo Master CPU
7. Using "MakeTurbo" or "MakeREU" to Make a New GEOS Boot Disk
8. Comment Regarding Compatibility

LIST OF FIGURES:

- FIG. 1. Side view of Master Adapter Installation  
FIGS. 2A & 2B. Configuration Jumpers for GEORAM Mode  
FIGS. 3A & 3B. Configuration Jumpers for Commodore 17xx REU Mode  
FIGS. 4A & 4B. Jumper Connection Inside Turbo Master CPU for 17xx REU Mode  
FIG. 5. Optional Modification to Turbo Master CPU

1. Brief Description

Master Adapter is a specialized two-slot buffered cartridge expander. Its only intended purpose is to allow a Turbo Master CPU 4 MHz processor accelerator cartridge running under GEOS to work with either a GEORAM from Berkeley Softworks (now GeoWorks) or a Commodore 17xx REU.

Master Adapter has two very distinct modes, a GEORAM mode and a Commodore 17xx REU mode. The particular mode is selected by a combination of configuration jumper setting (FIG. 2 or 3) and cartridge position. These instructions must be followed precisely. The internal circuit configuration is very different depending upon the mode.

Included on the disk are two test programs "TEST REU" and "TEST GEORAM" to allow you to test the Master Adapter hardware with your RAM expansion plugged in before you even try to boot GEOS. These test programs Load and Run like Basic programs, although they are written in assembly language. If no error occurs, the test programs run indefinitely. Use RUN/STOP-RESTORE to exit the test program.

For use with GEORAM, no additional driver program is required other than GEOS version 2.0r as supplied by Berkeley softworks. If you have an expanded GEORAM, any special version of the GEOS CONFIGURE program you ordinarily use should continue to be used. For GEORAM, it is not necessary to use the "MakeTurbo" procedure to make a new GEOS boot disk, but it is much more convenient.

For use with a Commodore 17xx REU, a special auto-exec "TurboREU" driver program is required and you must be using a GEOS boot disk made with the "MakeREU" procedure. Both "TurboREU" and "MakeREU" were written by Paul J. Bosacki and are supplied on the current Turbo Master demo/utilities disk. Use of "TurboREU" is described below in section 5. If you have an

expanded REU, any special version of the GEOS CONFIGURE program you ordinarily use should continue to be used in conjunction with "TurboREU".

Important: "MakeTurbo" and "MakeREU" are variations of the same program. However, "MakeTurbo" is for standard GEOS without a REU or GEOS 2.0r with a GEORAM. "MakeREU" is only for the combination of Turbo Master, Master Adapter and 17xx REU. Caution: Both "MakeTurbo" and "MakeREU" generate a file with the identical name "TURBOBOOT"; it is up to you to label your disk so you know which configuration it is for. When using "TurboREU" and the Commodore 17xx REU the "MakeREU" procedure must be used. For GEORAM, the corresponding "MakeTurbo" procedure is not required, but it is much more convenient. Even with a straight Turbo Master and no RAM expansion, the "MakeTurbo" procedure is recommended as a matter of convenience, now that it is available. The "MakeTurbo" procedure is described in the Turbo Master manual beginning with the October 1991 revision, and that information is repeated in modified form as Section 7 at the end of these supplement sheets.

## 2. Power Supply

We have always recommended use of a replacement power supply whenever Turbo Master CPU is used with a C64. (Even though the power consumption of Turbo Master CPU is within the rated capacity of a standard power supply, these power supplies are notoriously weak.) This paragraph is intended to emphasize the power supply recommendation when both a Turbo Master and RAM expansion are used. The power supply which comes with the Commodore 1764 REU is sufficient. However, GEORAM does not come with a replacement power supply because it is inherently a lower-power device, but when used with Turbo Master a replacement power supply should be used. A number are advertised in the magazines.

## 3. General Mechanical Configuration

Caution: Be certain power to your computer is turned OFF when installing Master Adapter or any cartridge product.

Physically Master Adapter consists of two circuit boards, a short horizontal one and a larger vertical one, plugged together at right angles. Ensure that the two boards are plugged tightly together upon installation, as the right angle connectors we were able to find do not have positive mechanical retention.

Refer to FIG. 1 for a right side view of the installation. The short horizontal board with gold edge connectors recesses nearly completely into the computer. It is oriented with its IC and connector on top.

Important: For GEORAM mode, Turbo Master must be on the bottom plugged into the lower slot, and GEORAM must be on top plugged into the upper slot. This is in addition to the configuration jumper setting of FIG. 2. The clip lead on Master Adapter is not used with GEORAM.

Important: For Commodore 17xx REU mode, the REU must be on the bottom plugged into the lower slot, and Turbo Master must be on top plugged into the upper slot. This is in addition to the configuration jumper setting of FIG. 3. In most cases the clip lead on Master Adapter is used with a Commodore 17xx REU, but there is an alternative procedure that involves adding a jumper inside Turbo Master CPU.

#### 4. Use With GEORAM

Important: GEORAM in upper slot  
Turbo Master in lower slot  
Four configuration jumpers per FIGS. 2A and 2B  
Clip lead not used

For GEORAM mode, the clip lead is not used, and may as well be removed if you are only using GEORAM. No internal changes to Turbo Master are required.

After assembling the system, Load and Run the test program "TEST GEORAM" from Basic. Each "OK" means a 256-byte block of data has been successfully transferred to and read from GEORAM. The data test pattern is varied for each "OK". The test program runs indefinitely. Use RUN/STOP-RESTORE to end.

To actually use with GEOS, no special software driver is required, other than GEOS 2.0r that is supplied with GEORAM. Use the CONFIGURE program you normally use. It is recommended that you use "MakeTurbo" to make a new GEOS boot disk from your original GEOS 2.0r disk.

In GEORAM mode, Master Adapter functions as a simple cartridge expander, except the Phase 2 clock from the C64 is buffered, unlike ordinary cartridge expanders. The RAM on the Master Adapter board is disabled.

#### 5. Use With Commodore 1700, 1764 or 1750 REU

Important: Turbo Master in upper slot  
REU in lower slot  
Four configuration jumpers per FIGS. 3A and 3B  
Clip lead or alternative used

For REU mode, an internal connection to Turbo Master CPU is required. This can be accomplished either by using the clip lead, or by adding a jumper inside Turbo Master.

Refer to FIGS. 4A and 4B for the clip lead connection inside the Turbo Master CPU accelerator. Remove the four cover screws, and locate the IC identified as U18MA. The clip lead connection is made to pin 6 of this IC. To make this connection, remove U18MA from its socket, and slightly bend pin 6 out so it does not engage the socket when you plug it back in. Replace the cover. Refer to FIG. 6 and Section 6 below for an alternative connection which eliminates the clip lead extending from the Master Adapter.

Note that the IC must be identified as U18MA and not plain U18. All Turbo Masters shipped since June 21, 1991 should have U18MA, as we by that time were anticipating the Master Adapter connection. If our records indicate you have an earlier Turbo Master with a plain U18, we are including a replacement U18MA with your Master Adapter. If you discover we have made a mistake, and that you have a plain U18, please contact us and we will immediately send you the replacement U18MA.

Also note if you have an original version Turbo Master, there is no U18 at all and the clip lead is not needed. Original version Turbo Masters are easily identified because they do not have a IC on the "tongue" of the board that protrudes out from the case.

After assembling the system, Load and Run the test program "TEST REU" from Basic. Each "OK" means a 256-byte block of data has been successfully transferred to and read from the REU. The data test pattern is varied for each "OK". The test program runs indefinitely. Use RUN/STOP-RESTORE to end.

To actually use with GEOS, the special software driver program "TurboREU" is required, and must be positioned on your boot disk directory ahead of CONFIGURE. Also, you must use the "MakeREU" procedure described in Section 7 below to make a new GEOS boot disk with "TURBOBOOT". This particular boot disk can be used only with (a) plain GEOS (no REU), or (b) GEOS with Master Adapter, REU and Turbo Master. If you attempt to use this boot disk with a REU in the normal manner (without Master Adapter), the system will crash. Note that you can use "MakeTurbo" and "MakeREU" to make several different boot disks to suit different configurations.

When using "MakeREU" to make your boot disk, run a clean system to ensure the "TURBOBOOT" file has the right code. This means do not use Turbo Master, and do not use an REU. Just a plain C64 and a standard GEOS 2.0 boot disk.

After you have made your new boot disk and positioned the proper files on it, then assemble the Master Adapter to the computer, plug in the REU and Turbo Master (including the clip lead), and reboot from the new boot disk. The first four files on the boot disk should be "BOOT", "TURBOBOOT", "TurboREU" and "CONFIGURE".

"TurboREU" is an auto-exec file and makes changes to the GEOS code in memory to access the REU in a non-standard way for use with Master Adapter. It is for this reason that "TurboREU" must be placed in the disk directory ahead of CONFIGURE so that when CONFIGURE auto-execs it will be able to find the REU.

This paragraph will attempt to briefly explain the technical aspects of Master Adapter in REU mode. An ordinary cartridge expander will not work because the Commodore REU is a DMA device and has no way to directly access the 64K RAM on board the Turbo Master CPU accelerator. Another problem is that Turbo Master asserts the DMA line on the C64 100% of the time, and so the REU could not share this line. Not accepting "no" for an answer, Paul Bosacki conceived the principle of the Master Adapter. Master Adapter has on it a small 256-byte RAM addressed at \$DExx, and this small RAM is visible to both the REU and the Turbo Master. (The actual RAM chip used is a 2K x 8 static RAM, which is the smallest one we could find. All but 256 bytes are disabled.) All data transfer between Turbo Master and the REU goes through this small RAM. Thus to transfer data from the 64K RAM in the turbo to the REU, the software must first copy the data to \$DExx, and then set the REU control registers (\$DFxx range) to cause the REU to transfer the data from \$DExx to the appropriate address in the REU. The opposite procedure is used to transfer data from the REU to the 64K RAM in the turbo. The "TurboREU" and "MakeREU" software drivers are set up to do these special transfers, but this could be done from any program. Logic circuitry on the Master Adapter avoids bus conflicts. When the REU asserts the DMA line to indicate it needs the bus, the Master Adapter circuitry routes this signal to the BA input on the turbo, which is fooled into thinking the VIC chip needs the bus and so the turbo relinquishes the bus to allow REU access.

There may be times when you will want to DISABLE Turbo Master and have normal access to the REU. To do this, set the configuration jumpers per FIGS. 2A and 2B as if for GEORAM, but leave Turbo Master in the upper slot position. This can be viewed as a non-standard configuration.



## 6. Optional Modification to Turbo Master CPU

This section applies to REU users only, not GEORAM users. Pin 8 on the Turbo Master CPU edge connector is normally unused (it's assigned to the GAME line which Turbo Master doesn't implement). The Master Adapter board also brings the clip lead line to pin 8 of the upper 44-pin edge connector socket. So, with care, you can remove the clip lead end from the Master Adapter board, and very carefully solder it to the inside end of pad 8 on the edge connector, taking care not to get solder on the part of the edge connector that plugs into the socket. Refer to FIG. 5. This modification will allow you to more easily plug the Turbo Master into and out of the Master Adapter.

Possible future production of Turbo Masters may have this connection made as part of the circuit board. It's not something we anticipated prior to the Master Adapter design.

## 7. Using "MakeTurbo" or "MakeREU" to Make a New GEOS Boot Disk

"MakeTurbo" and "MakeREU" provide a way to quickly and simply boot GEOS for operation at 4 MHz. Unlike the earlier "PATCH GEOS" and "AUTO PATCH" procedures, there is no need to flip the manual speed change switches on the accelerator, nor is there any need to install a patch as part of the actual boot process after you have initially made a new boot disk. "MakeTurbo" and "MakeREU" were written by Paul J. Bosacki, who also wrote GEOS GATEWAY sold by CMD.

"MakeTurbo" and "MakeREU" are variations of the same program. "MakeTurbo" is for standard GEOS without a REU or GEOS 2.0r with a GEORAM. "MakeREU" is only for the combination of Turbo Master, Master Adapter and 17xx REU. Caution: Both "MakeTurbo" and "MakeREU" generate a file with the identical name "TURBOBOOT"; it is up to you to label your disk so you know which configuration it is for.

You will need at least the following two files:

BOOT (a regular C64 file)  
MakeTurbo or MakeREU (a GEOS application file)

If you are making a boot disk to use with Master Adapter and a 17xx Commodore REU, you will also need the file:

TurboREU (a GEOS auto-exec file)

In addition you will need a fresh disk, which will become your new boot disk. The new boot disk can be for 1541, 1571 or even 1581! Likely it could even be an area on a CMD Hard Drive. The only limitation is that the new boot disk cannot be formatted as 1571 double-sided. This is a limitation of GEOS itself, for reasons that are not understood.

**Here's how to make your new boot disk.** Since GEOS is not yet patched for operation at 4 MHz, while doing these procedures you must either have your accelerator switched to MANUAL 1 MHz, or have the accelerator set to DISABLE, or be running in a plain C64 (preferred). When you are done, GEOS will quickly boot at 4 MHz.

**1) Prepare your new boot disk as a freshly-formatted GEOS disk.** Any format except 1571 double-sided. 1571 single-sided is fine.

2) Use GEOS to copy the following files onto the new boot disk:

**BOOT**

either MakeTurbo (for GEORAM or no RAM expansion) or MakeREU (for REU) TurboREU (only for REU and Master Adapter, not for GEORAM)

It will be more convenient if BOOT is the first file on the disk. MakeTurbo or MakeREU can initially be the second file, but you may later want to move it to another position, or delete it altogether. TurboREU, if used, should be the third file, and must be put on the directory ahead of CONFIGURE.

3) Copy to the new boot disk any other files you would normally have on a boot disk. These should include CONFIGURE, deskTop, your printer driver, and your input driver. It is best if the copy of CONFIGURE that you copy to the boot disk has your configuration previously saved to it. For example, Drive B as RAM 1541 or RAM 1571. If you use several input drivers, your preferred default should be first. Don't fill the new boot disk too full; leave at least 22 K bytes free. The new boot disk should not have the usual boot files GEOS, GEOS BOOT and GEOS KERNAL. These are all replaced by BOOT and, initially, MakeTurbo or MakeREU.

4) Re-boot GEOS normally from an original Berkeley GEOS disk to ensure a "clean" unmodified Kernal, with no patches. This means the only auto-exec file should be CONFIGURE. Do not have an REU plugged in at this point. No patches at all should be installed. (You cannot be running at 4 MHz for this procedure, and may as well be running in a plain C64 without a Turbo Master CPU.) You may wish to set the system date and time, as these will be date stamped on the created boot file. Be sure to use GEOS 2.0 if you are making a boot disk for the REU, and use GEOS 2.0r if you are making a boot disk for GEORAM.

4A) If you are using GATEWAY from Creative Micro Designs (also written by Paul Bosacki), do this procedure from the GATEWAY when making your new boot disk.

5) Open your new boot disk on the type of drive it will be for (1541, 1571 or 1581). Then double click on MakeTurbo (for a GEORAM version) or MakeREU (for an REU version). After a short while, the program will exit back to deskTop. A new file, named TURBOBOOT, will be on your disk. This is a captured version of the GEOS Kernal, keyed to your applications, and already patched to load and run at 4 MHz.

Archive away your original GEOS boot disk! To boot GEOS, insert the new boot disk, and enter LOAD "BOOT",8,1. Or, if BOOT is the first file on the disk, use the SHIFT-RUN/STOP key combination. In either case, the process proceeds quickly and automatically. The switches on Turbo Master CPU can be set to SOFT 4 MHz throughout the boot process.

**MakeTurbo/MakeREU Notes:**

1) The resident GEOS disk driver will be saved as part of the TURBOBOOT file. This means that you must later boot from the same type of drive (i.e. 1541 or 1571) that was active when you created your new boot disk. A boot disk created on a 1571 drive will not boot on a 1541 drive, or vice versa. So if you have these different drive types, it is important to properly label your boot disk. With a 1581 no confusion is possible because the disk size is unique.

2) The new GEOS boot file does not include a turbo loader, and so will load at normal DOS speed in the absence of another turbo loader. This ensures compatibility with all disk drives. Normally, however, either the fast disk loader in Turbo Master CPU will be turned ON (using the @6 wedge command), or JiffyDOS will be in use. Once inside GEOS, the resident Turbo DOS takes over.

3) You can make multiple boot disks for different configurations. For example, different boot disks for GEOS 2.0 and 2.0r, or even different boot disks for different drive configurations, which can be simpler than using CONFIGURE to change.

4) "MakeTurbo" determines the GEOS kernal version under which it has been launched. Having done so, InitForIO and DoneWithIO patches are installed into unused regions of the Kernal. In the case of GEOS 2.0, this region starts at \$CBE0. In GEORAM GEOS 2.0r, the region used starts at \$CFE0.

5) "MakeTurbo" and "MakeREU" are only for the GEOS 2.0 and 2.0r versions.

6) After you have created the new boot disk, other auto-exec files can be placed on it, so long as they are positioned after CONFIGURE. (Except TurboREU should be positioned before CONFIGURE if you are also using a Commodore 17xx REU and a Master Adapter).

7) You may want to move the new boot file TURBOBOOT to the second position in the directory in place of MakeTurbo or MakeREU. MakeTurbo or MakeREU is no longer needed once it has done its job of creating TURBOBOOT.

8) Comment Regarding Compatibility

GEOS is a very demanding application for the computer hardware. When running GEOS in the Turbo Master CPU accelerator, it is not unusual for minor problems like extraneous screen characters to appear. Master Adapter adapter cannot improve this situation; it can only make it worse.

Unfortunately we do expect there will be a number of C64 systems that simply will not work with Master Adapter, particularly in REU mode. If yours is one of these, there is nothing we will be able to do, except of course to take the unit back for a refund.

If you do experience problems, first ensure that everything is plugged together tightly.

FIG. 1. Side View of Master Adapter Installation

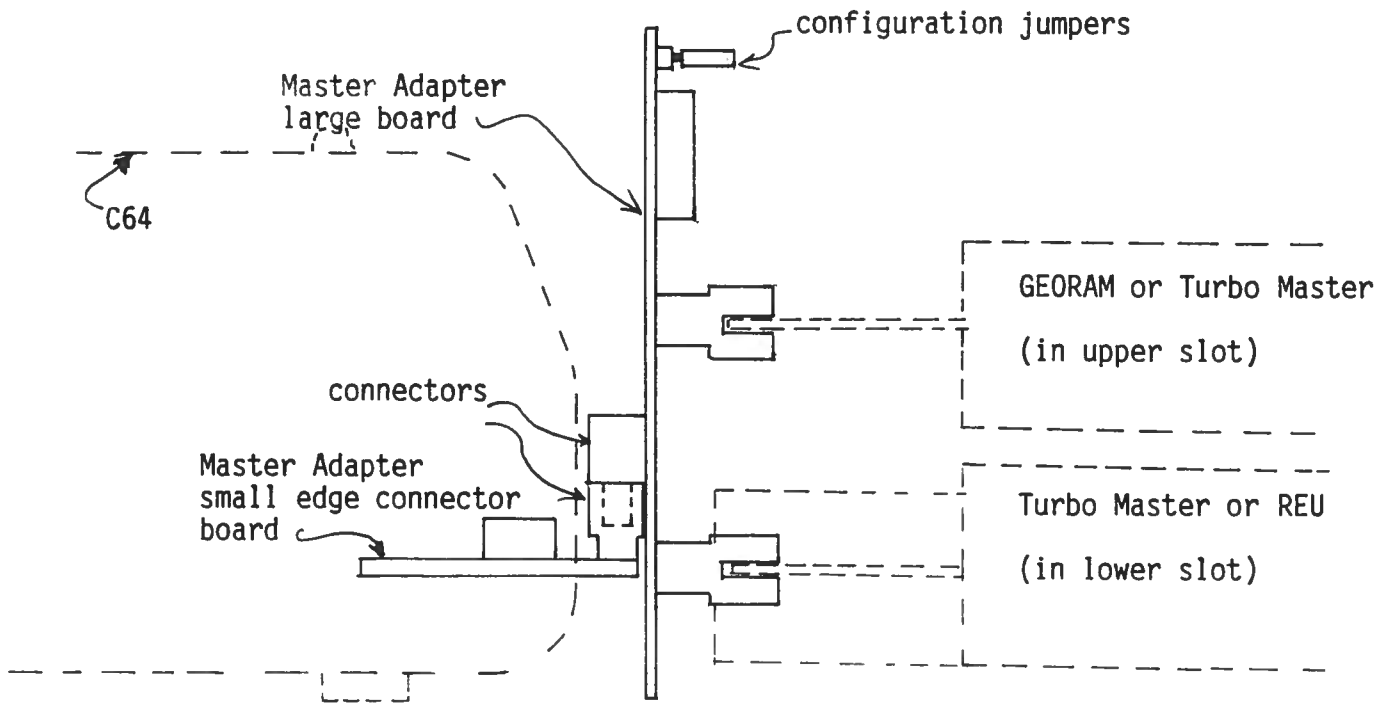

FIG. 2A  
Top view of GEORAM configuration



FIG. 3A Top view of REU config.

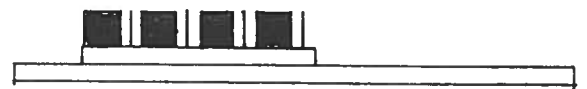

FIG. 2B  
Socket side view of GEORAM configuration

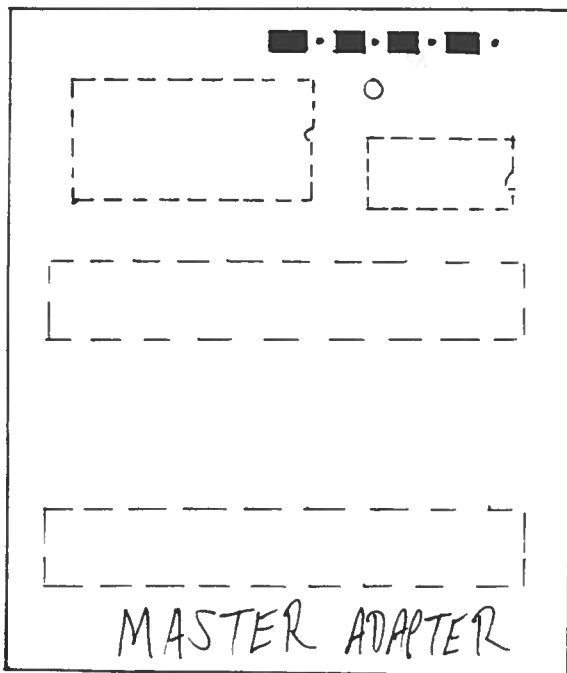

FIG. 3B  
Socket side view of REU configuration

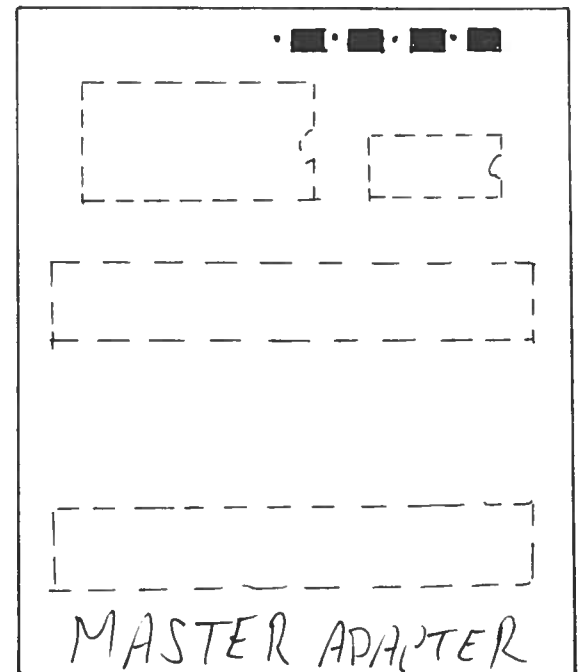



FIG. 4A. Identifying location of U18MA inside Turbo Master CPU for jumper connection to pin 6. (Replace plain U18 with U18MA, if applicable.)

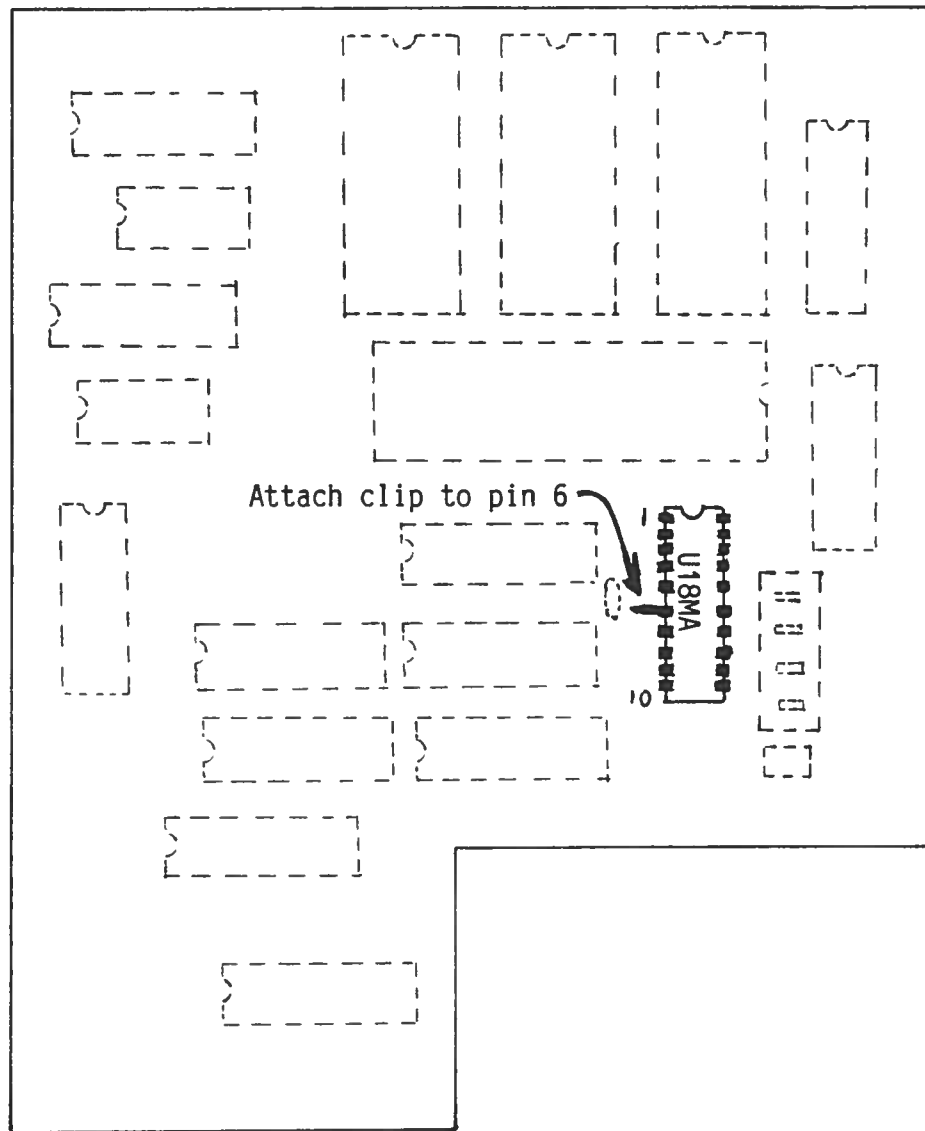
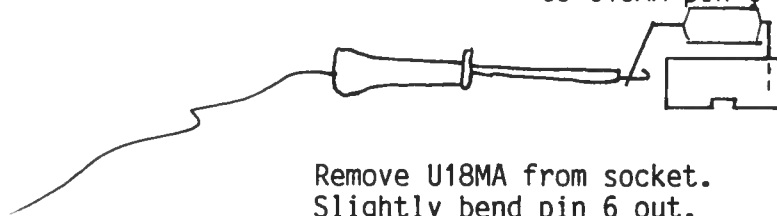

FIG. 4B  
Side view of clip connection  
to U18MA pin 6



Remove U18MA from socket.  
Slightly bend pin 6 out.  
Plug U18MA back in, with pin slightly clear  
of socket.  
(Socket pin 6 is tied to +5 volts.)

FIG. 5 Optional jumper inside Turbo Master for REU use with Master Adapter.

End of clip lead wire is removed from Master Adapter and carefully soldered to pin 8.

