

SERVICE MANUAL

**1581
3.5 DISK DRIVE**

JUNE 1987

PN-314982-01

 **commodore**
COMPUTERS

SERVICE MANUAL

1581

3.5 DISK DRIVE

JUNE 1987

PN-314982-01

Commodore Business Machines, Inc.

1200 Wilson Drive, West Chester, Pennsylvania 19380 U.S.A.

Commodore makes no expressed or implied warranties with regard to the information contained herein. The information is made available solely on an as is basis, and the entire risk as to quality and accuracy is with the user. Commodore shall not be liable for any consequential or incidental damages in connection with the use of the information contained herein. The listing of any available replacement part herein does not constitute in any case a recommendation, warranty or guaranty as to quality or suitability of such replacement part. Reproduction or use without expressed permission, of editorial or pictorial content, in any matter is prohibited.

This manual contains copyrighted and proprietary information. No part of this publication may be reproduced, stored in a retrieval system, or transmitted in any form or by any means, electronic, mechanical, photocopying, recording or otherwise, without the prior written permission of Commodore Electronics Limited.

Copyright © 1987 by Commodore Electronics Limited.
All rights reserved.

TABLE OF CONTENTS

TITLE	PAGE
GENERAL SPECIFICATIONS	
CHARACTERISTICS	1
HARDWARE SUMMARY	1
SPECIFICATIONS	1
FORMAT ORGANIZATION	2
MEMORY MAP — I/O	2
MEMORY MAP — RAM	3
SERIAL INTERFACE	3
PROGRAMMABLE BAUD RATE	4
SELF TEST DIAGNOSTICS	4
CHIP SPECIFICATIONS	
6502 MPU	5
8520A CIA	7
WD1770 FDC	9
PARTS LIST — MAJOR/COMPONENT	12
ASSEMBLY DRAWING	13
BOARD LAYOUT	14
SCHEMATICS	15

GENERAL SPECIFICATIONS

1 CHARACTERISTICS

- A) 3.5 inch, +800K storage
- B) Increased buffers, fixed BAM locations
- C) Expanded controller commands
- D) Track cache buffer
- E) Configurable auto boot file
- F) User alterable physical/logical track and sector translation
- G) Fully vectored jump table
- H) Partition capabilities
- I) Wild card enhancements
- J) Standard, fast and burst serial capabilities
- K) Expanded burst command set

2 HARDWARE SUMMARY

PROCESSORS: 6502A, WD1770
ROM: 32K
RAM: 8K
I/O: 8520A

3 SPECIFICATIONS

GROSS DATA ORGANIZATION:

3.5 Inch Disk
Double-Sided
80 Cylinders/160 Tracks

PER TRACK ORGANIZATION:

Hex 4E written as a gap, with 10 sectors of data, with full gaps written for motor speed variation.

PER SECTOR ORGANIZATION:

MFM Encoding
12 Bytes of 00
3 Bytes of Hex A1 (Data Hex A1, Clock Hex 0A)
1 Byte of FE (ID Address Mark)
1 Byte (Track Number)
1 Byte (Side Number)
1 Byte (Sector Number)
1 Byte (Sector Length, 02 for 512 Byte Sectors)
2 Bytes CRC (Cyclic Redundancy Check)
22 Bytes of Hex 22

3 SPECIFICATIONS (continued)

- 12 Bytes of 00
- 3 Bytes of Hex A1 (Data Hex A1, Clock Hex 0A)
- 1 Byte of Hex FB (Data Address Mark)
- 512 Bytes of Data
- 2 Bytes of CRC (Cyclic Redundancy Check)
- 38 Bytes of Hex 4E

4 FORMAT ORGANIZATION

PHYSICAL:

- Cylinders 0 thru 79
- Sectors 1 thru 10 on Side 1
- Sectors 1 thru 10 on Side 2
- Sector Size 512

LOGICAL:

- Tracks 1 thru 80
- Sectors 0 thru 39 (Using physical Sectors 1...10 — Side 1 and 2)
- Sector Size 256 Bytes

STORAGE:

Total Unformatted Capacity	1 Megabyte
Total Formatted Capacity	808, 960 Bytes
Maximum Sequential File Size	802, 640 Bytes
Maximum Relative File Size	182, 880 Bytes
Records Per File	65, 535
Files Per Diskette	*296
Cylinders Per Diskette	80
Logical Sectors Per Cylinder	40
Physical Sectors Per Cylinder	20
Logical Bytes Per Sector	256
Physical Bytes Per Sector	512
Free Blocks Per Disk	3160

*More with Sub-Disk Partitioning

5 MEMORY MAP — I/O LOCATIONS

8K x 8 RAM	\$0002-\$1FFF	
8520A	\$4000-\$4010	Controller, Serial Bus
WD 1770	\$6000-\$6003	MFM Disk Controller
32K x 8 ROM	\$8000-\$FFFF	DOS, Controller Code

6 MEMORY MAP — RAM USAGE

\$0002-\$00FF	Zero Page Variables
\$0100-\$01FF	Vectors, Variables and Stack Area
\$0200-\$02FF	Command/Error Buffer and Variables
\$0300-\$03FF	Buffer #0
\$0400-\$04FF	Buffer #1
\$0500-\$05FF	Buffer #2
\$0600-\$06FF	Buffer #3
\$0700-\$07FF	Buffer #4
\$0800-\$08FF	Buffer #5
\$0900-\$09FF	Buffer #6
\$0A00-\$0AFF	BAM
\$0B00-\$0BFF	BAM
\$0C00-\$1FFF	Track Cache Buffer

7 COMMODORE SERIAL INTERFACE

The 1581 supports Standard, Fast, and Fast Serial communication like the 1571.

A HRF (Host Request Fast) command places the drive in fast serial mode. The 1581 remains in fast serial mode until an Unlisten, Untalk, or serial bus error. The 1581 will also source a DRF (Device Request Fast) message. This message lets the host know that the addressed peripheral can receive bytes fast (or slow).

The bus consists of the following:

PIN 1 — SRQ (Service Request)

Unused by the current serial bus. Fast serial will use this line as a bi-direction fast clock line.

PIN 2 — GND

Chassis ground.

PIN 3 — ATN (in)

The host brings this signal low which then generates an interrupt on the controller board. The attention sequence is followed by an address. If the device does not respond within a preset time, the host will assume the device addressed is not on the bus.

PIN 4 — CLK (in/out)

This signal is used for timing the data sent on the serial bus (software clocked).

PIN 5 — DATA (in/out)

Data on the serial bus is transmitted one bit at a time (software toggled). In addition, this line is wire 'ored' and used as a FAST DATA line to compliment the FAST CLOCK on the SRQ line.

PIN 6 — RESET

This line will reset the peripheral upon host reset.

8 PROGRAMMABLE BAUD RATE GENERATOR

The 8520 contains a programmable baud rate generator which is used for fast serial transfers. Timer A is used for the baud rate generator. In the output mode data is shifted out on SP at 1/2 the underflow rate of Timer A. The maximum baud rate possible is $\phi 2$ divided by 4, but the maximum usable baud rate will be determined by line loading and the speed at which the receiver responds to the input data. Transmission will start following a write to the Serial Data Register (provided Timer A is running and in continuous mode). The clock derived from Timer A appears on the CNT pin. The Data in the Serial Data Register will be loaded into the shift register then shifted out to the SP pin. After 8 pulses on the CNT pin, a bit in the ICR (interrupt control register) is set and if desired, an interrupt may be generated. All incoming fast bytes generate an interrupt within the Fast Serial Drive. Bytes are shifted out; most significant bit first.

NOTE: When the 8520 is put in output mode the SP pin (data) will go low.

Baud Rate	Hi Timer Value	Low Timer Value
Phi2 = 2MHz		
166k	00	06
143k	00	07
100k	00	10
50k	00	20
25k	00	40
12.5k	00	80

9 SELF TEST DIAGNOSTICS

The 1581 performs a self-test of RAM, ROM, and Controller. If an error is detected, the DOS will blink all LED's a specific number of times. The flash code is repeated continuously.

# OF FLASHES	RESOURCE	COMPONENT
1	Zero Page	8K x 8 RAM
2	ROM	25256
3	100H-1FFFH	8K x 8 RAM

In addition, the 1581 performs a Controller Test. If a failure is detected, the error channel will contain 76, controller error 00,00. If an extensive test of ROM is required, the 1581 provides a signature analysis via command 'UO>T'. If a failure is detected, the LED's will blink 4 times continuously.

6502 MICROPROCESSOR

Features of 6502

- 65K Addressable Bytes of Memory (A0-A15)
- \overline{IRQ} Interrupt
- On-the-chip Clock
 - TTL Level Single Phase Input
 - RC Time Base Input
 - Crystal Time Base Input
- SYNC Signal
(can be used for single instruction execution)
- RDY Signal
(can be used to halt or single cycle execution)
- Two-Phase Output Clock for Timing of Support Chips
- \overline{NMI} Interrupt

VSS	1	40	\overline{RES}
RDY	2	39	$\phi 2$ (OUT)
$\phi 1$ (OUT)	3	38	S.O.
\overline{IRQ}	4	37	$\phi 0$ (IN)
N.C.	5	36	N.C.
\overline{NMI}	6	35	N.C.
SYNC	7	34	R/W
VCC	8	33	D0
A0	9	32	D1
A1	10	31	D2
A2	11	30	D3
A3	12	29	D4
A4	13	28	D5
A5	14	27	D6
A6	15	26	D7
A7	16	25	A15
A8	17	24	A14
A9	18	23	A13
A10	19	22	A12
A11	20	21	VSS

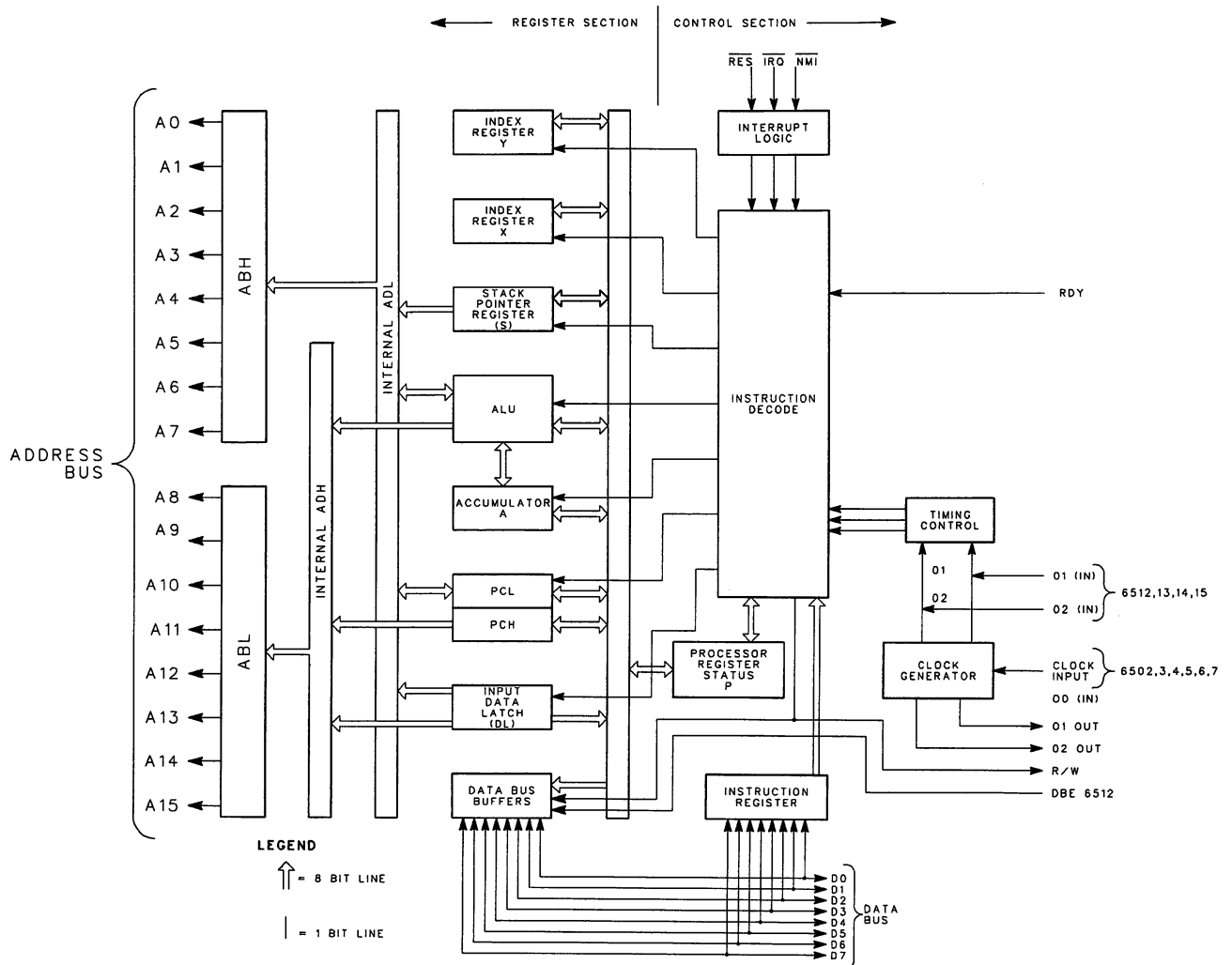

6502 SIGNAL DESCRIPTION

Clocks (O_1 , O_2) — The 651X requires a two phase non-overlapping clock that runs at the Vcc voltage level. The 650X clocks are supplied with an internal clock generator. The frequency of these clocks is externally controlled.

Address Bus (A_0 - A_{15}) — These outputs are TTL compatible, capable of driving one standard TTL load and 130 pf.

Data Bus (D_0 - D_7) — Eight pins are used for the data bus. This is a bi-directional bus, transferring data to and from the device and peripherals. The outputs are tri-state buffers capable of driving one standard TTL load and 130 pf.

Data Bus Enable (DBE) — This TTL compatible input allows external control of the tri-state data output buffers and will enable the microprocessor bus driver when in the high state. In normal operation, DBE would be driven by the phase two (O_2) clock, thus allowing data output from microprocessor only during O_2 . During the read cycle, the data bus drivers are internally disabled, becoming essentially an open circuit. To disable data bus drivers externally, DBE should be held low.

Ready (RDY) — This input signal allows the user to single cycle the microprocessor on all cycles except write cycles. A negative transition to the low state during, or coincident with, phase one (O_1) and up to 100ns after phase two (O_2) will halt the microprocessor with the output address lines reflecting the current address being fetched. This condition will remain through a subsequent phase two (O_2) in which the Ready signal is low. This feature allows microprocessor interfacing with low speed PROMS as well as fast (max. 2 cycle) Direct Memory Access (DMA). If Ready is low during a write cycle, it is ignored until the following read operation.

Interrupt Request (\overline{IRQ}) — This TTL level input requests that an interrupt sequence begin within the microprocessor. The microprocessor will complete the current instruction being executed before recognizing the request. At that time, the interrupt mask bit in the Status Code Register will be examined. If the interrupt mask flag is not set, the microprocessor will begin an interrupt sequence. The Program Counter and Processor Status Register are stored in the stack. The microprocessor will then set the interrupt mask flag high so that no further interrupts may occur. At the end of this cycle, the program counter low will be loaded from address FFFE, and program counter high from location FFFF, therefore, transferring program control to the memory vector located at these addresses. The RDY signal must be in high state for any interrupt to be recognized. A 3K Ω external resistor should be used for proper wire-OR operation.

Non-Maskable Interrupt (\overline{NMI}) — A negative going edge on this input requests that a non-maskable interrupt sequence be generated within the microprocessor. \overline{NMI} is an unconditional interrupt. Following completion of the current instruction, the sequence of operations defined for \overline{IRQ} will be performed, regardless of the interrupt mask flag status. The vector address loaded into the program counter, low and high, are locations FFFA and FFFB respectively, thereby transferring program control to the memory vector located at these addresses. The instructions loaded at these locations cause the microprocessor to branch to a non-maskable interrupt routine in memory. \overline{NMI} also requires an external 3K Ω resistor to Vcc for proper wire-OR operations. Inputs \overline{IRQ} and \overline{NMI} are hardware interrupt lines that are sampled during O_2 (phase 2) and will begin the appropriate interrupt routine on the O_1 (phase 1) following the completion of the current instruction.

Set Overflow Flag (S.O.) — A NEGATIVE going edge on this input sets the overflow bit in the Status Code Register. This signal is sampled on the trailing edge of O_1 .

SYNC — This output line is provided to identify those cycles in which the microprocessor is doing an OP CODE fetch. The SYNC line goes high during O_1 of an OP CODE fetch and stays high for the remainder of that cycle. If the RDY line is pulled low during the O_1 clock pulse in which SYNC went high, the processor will stop in its current state and will remain in the state until the RDY line goes high. In this manner, the SYNC signal can be used to control RDY to cause single instruction execution.

Reset — This input is used to reset or start the microprocessor from a power down condition. During the time that this line is held low, writing to or from the microprocessor is inhibited. When a positive edge is detected on the input, the microprocessor will immediately begin the reset sequence. After a system initialization time of six clock cycles, the mask interrupt flag will be set and the microprocessor will load the program counter from the memory vector locations FFFC and FFFD. This is the start location for program control. After Vcc reaches 4.75 volts in a power up routine, reset must be held low for at least two clock cycles. At this time the R/W and (SYNC) signal will become valid. When the reset signal goes high following these two clock cycles, the microprocessor will proceed with the normal reset procedure detailed above.

8520A COMPLEX INTERFACE ADAPTER

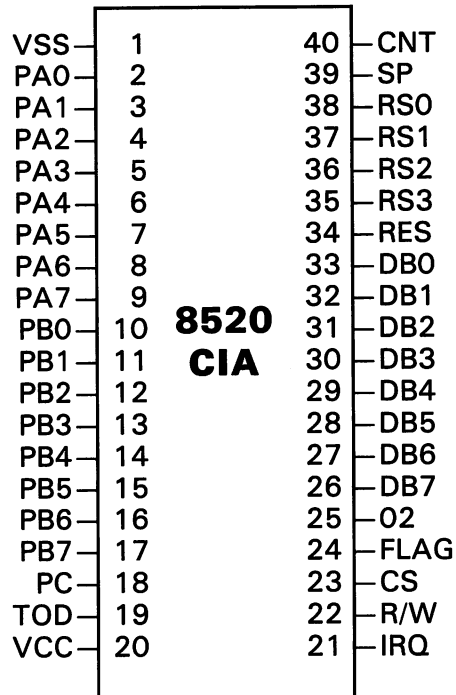

INTERFACE SIGNALS

O2 Clock Input — The O2 clock is a TTL, compatible input used for internal device operation and as a timing reference for communicating with the system data bus.

CS — Chip Select Input — The CS input controls the activity of the 8520. A low level on CS while O2 is high causes the device to respond to signals on the R/W and address (RS) lines. A high on CS prevents these lines from controlling the 8520. The CS line is normally activated (low) at O2 by the appropriate address combination.

R/W — Read/Write Input — The R/W signal is normally supplied by the microprocessor and controls the direction of data transfers of the 8520. A high on R/W indicates a read (data transfer out of the 8520), while a low indicates a write (data transfer into the 8520).

RS3-RS0 — Address Inputs — The address inputs select the internal registers as described by the Register Map.

DB7-DB0 — Data Bus Inputs/Outputs — The eight bit data bus transfers information between the 8520 and the system data bus. These pins are high impedance inputs unless CS is low and R/W and O2 are high, to read the device. During this read, the data bus output buffers are enabled, driving the data from the selected register onto the system data bus.

IRQ — Interrupt Request Output — IRQ is an open drain output normally connected to the processor interrupt input. An external pullup resistor holds the signal high, allowing multiple IRQ-outputs to be connected together. The IRQ output is normally off (high impedance) and is activated low as indicated in the functional description.

RES — Reset Input — A low on the RES pin resets all internal registers. The port pins are set as inputs and port registers to zero (although a read of the ports will return all highs because of passive pullups). The timer control registers are set to zero and the timer latches to all ones. All other registers are reset to zero.

REGISTER MAP

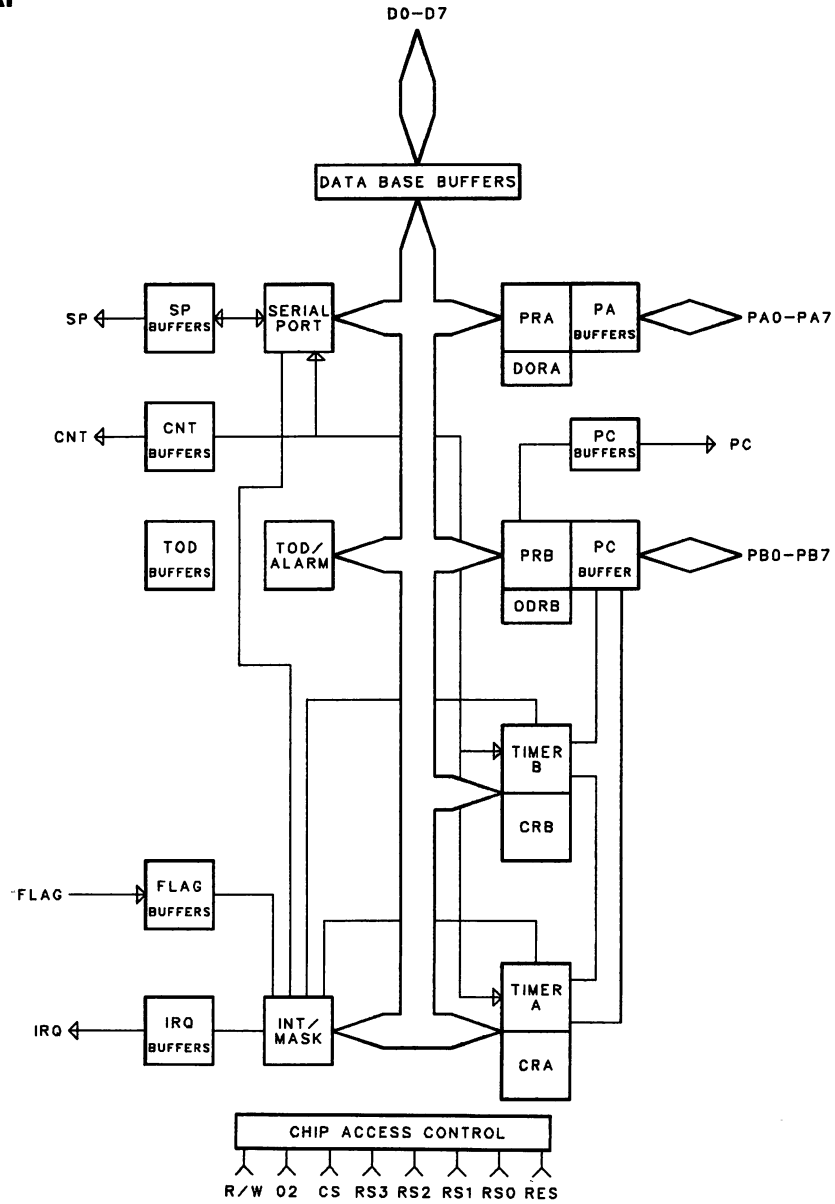

RS3	RS2	RS1	RS0	REG	
0	0	0	0	0	PRA Peripheral Data Reg. A
0	0	0	1	1	PRB Peripheral Data Reg. B
0	0	1	0	2	DDRA Data Direction Reg. A
0	0	1	1	3	DDRB Data Direction Reg. B
0	1	0	0	4	TA LO Timer A Low Register
0	1	0	1	5	TA HI Timer A High Register
0	1	1	0	6	TB LO Timer B Low Register
0	1	1	1	7	TB HI Timer B High Register
1	0	0	0	8	Event LSB
1	0	0	1	9	Event 8-15
1	0	1	0	A	Event MSB
1	0	1	1	B	No Connect
1	1	0	0	C	SDR Serial Data Register
1	1	0	1	D	ICR Interrupt Control Register
1	1	1	0	E	CRA Control Register A
1	1	1	1	F	CRB Control Register B

WD1770 FLOPPY DISK CONTROLLER

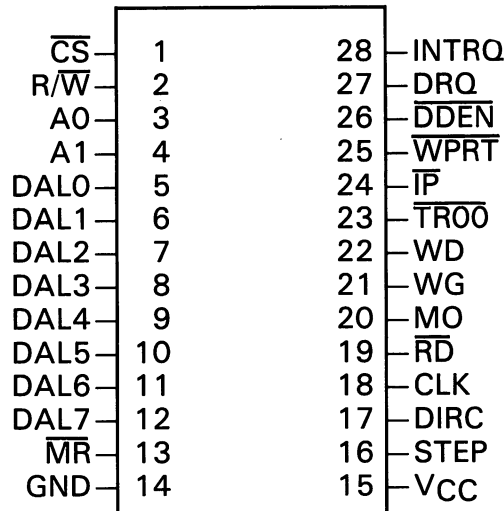

1	CS	CHIP SELECT	A logic low on this input selects the chip and enable Host communication with the device.																									
2	R/W	READ/WRITE	A logic high on this input controls the placement of data on the D0-D7 lines from a selected register, while a logic low causes a write operation to a selected register.																									
3,4	A0,A1	ADDRESS 0,1	These two inputs select a register to Read/Write data: <table border="1" style="margin-left: 40px;"> <thead> <tr> <th>CS</th> <th>A1</th> <th>A0</th> <th>R/W = 1</th> <th>R/W = 0</th> </tr> </thead> <tbody> <tr> <td>0</td> <td>0</td> <td>0</td> <td>Status Reg</td> <td>Command Reg</td> </tr> <tr> <td>0</td> <td>0</td> <td>1</td> <td>Track Reg</td> <td>Track Reg</td> </tr> <tr> <td>0</td> <td>1</td> <td>0</td> <td>Sector Reg</td> <td>Sector Reg</td> </tr> <tr> <td>0</td> <td>1</td> <td>1</td> <td>Data Reg</td> <td>Data Reg</td> </tr> </tbody> </table>	CS	A1	A0	R/W = 1	R/W = 0	0	0	0	Status Reg	Command Reg	0	0	1	Track Reg	Track Reg	0	1	0	Sector Reg	Sector Reg	0	1	1	Data Reg	Data Reg
CS	A1	A0	R/W = 1	R/W = 0																								
0	0	0	Status Reg	Command Reg																								
0	0	1	Track Reg	Track Reg																								
0	1	0	Sector Reg	Sector Reg																								
0	1	1	Data Reg	Data Reg																								
5-12	DAL0-DAL7	DATA ACCESS LINES 0 THRU 7	Eight bit bidirectional bus used for transfer of data, control, or status. This bus is enabled by CS and R/W. Each line will drive one TTL load.																									
13	MR	MASTER RESET	A logic low pulse on this line resets the device and initializes the status register (internal pull-up).																									
14	GND	GROUND	Ground.																									
15	VCC	POWER SUPPLY	+5V \pm 5% power supply input.																									
16	STEP	STEP	The Step output contains a pulse for each step of the drive's RW head. The WD1770 and WD1772 offer different step rates.																									
17	DIRC	DIRECTION	The Direction output is high when stepping in towards the center of the diskette, and low when stepping out.																									
18	CLK	CLOCK	This input requires a free-running 50% duty cycle clock (for internal timing) at 8 MHZ \pm 1%.																									
19	RD	READ DATA	This active low input is the raw data line containing both clock and data pulses from the drive.																									
20	MO	MOTOR ON	Active high output used to enable the spindle motor prior to read, write or stepping operations.																									
21	WG	WRITE GATE	This output is made valid prior to writing on the diskette.																									
22	WD	WRITE DATA	FM or MFM clock and data pulses are placed on this line to be written on the diskette.																									
23	TROO	TRACK00	This active low input informs the WD1770 that the drive's R/W heads are positioned over Track zero (internal pull-up).																									
24	IP	INDEX PULSE	This active low input informs the WD1770 when the physical index hole has been encountered on the diskette (internal pull-up).																									
25	WPRT	WRITE PROTECT	This input is sampled whenever a Write Command is received. A logic low on this line will prevent any Write Command from executing (internal pull-up).																									
26	DDEN	DOUBLE DENSITY ENABLE	This input pin selects either single (FM) or double (MFM) density. When DDEN = 0, double density is selected (internal pull-up).																									
27	DRQ	DATA REQUEST	This Active high output indicates that the data register is full (on a READ) or empty (on a Write operation).																									
28	INTRQ	INTERRUPT REQUEST	This Active high output is set at the completion of any command or reset or read of the status register.																									

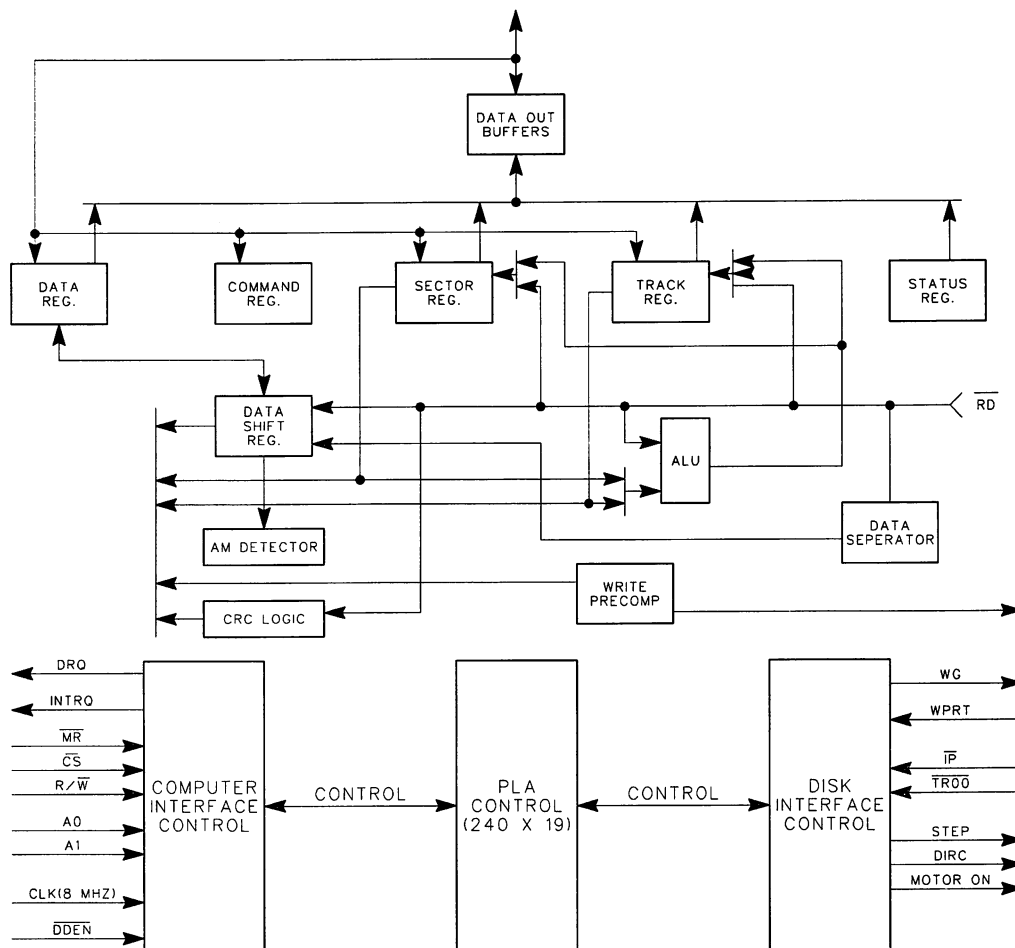

ARCHITECTURE

The Floppy Disk Formatter block diagram is illustrated on page 11. The primary sections include the parallel processor interface and the Floppy Disk Interface.

Data Shift Register — This 8-bit register assembles serial data from the Read Data input (\overline{RD}) during Read operations and transfers serial data to the Write Data output during Write operations.

Data Register — This 8-bit register is used as a holding register during Disk Read and Write operations. In Disk Read operations, the assembled data byte is transferred in parallel to the Data Register from the Data Shift Register. In Disk Write operations, information is transferred in parallel from the Data Register to the Data Shift Register.

When executing the Seek command, the Data Register holds the address of the desired Track position. This register is loaded from the DAL and gated onto the DAL under processor control.

Track Register — This 8-bit register holds the track number of the current Read/Write head position. It is incremented by one every time the head is stepped in and decremented by one when the head is stepped out (towards track 00). The contents of the register are compared with the recorded track number in the ID field during disk Read, Write, and Verify operations. The Track Register can be loaded from or transferred to the DAL. This Register should not be loaded when the device is busy.

Sector Register (SR) — This 8-bit register holds the address of the desired sector position. The contents of the register are compared with the recorded sector number in the ID field during disk Read or Write operations. The Sector Register contents can be loaded from or transferred to the DAL. This register should not be loaded when the device is busy.

Command Register (CR) — This 8-bit register holds the command presently being executed. This register should not be loaded when the device is busy unless the new command is a force interrupt. The command register can be loaded from the DAL, but not read onto the DAL.

Status Register (STR) — This 8-bit register holds device Status information. The meaning of the Status bits is a function of the type of command previously executed. This register can be read onto the DAL, but not loaded from the DAL.

CRC Logic — This logic is used to check or to generate the 16-bit Cyclic Redundancy Check (CRC). The polynomial is:

$$G(x) = x^{16} + x^{12} + x^5 + 1.$$

The CRC includes all information starting with the address mark and up to the CRC characters. The CRC register is preset to ones prior to data being shifted through the circuit.

Arithmetic/Logic Unit (ALU) — The ALU is a serial comparator, incrementor, and decrementor, and is used for register modification and comparisons with the disk recorded ID field.

Timing and Control — All computer and Floppy Disk interface controls are generated through this logic. The internal device timing is generated from an external crystal clock. The FD1770 has two different modes of operation according to the state of \overline{DDEN} . When $\overline{DDEN} = 0$, double density (MFM) is enabled. When $\overline{DDEN} = 1$, single density is enabled.

AM Detector — The address mark detector detects ID, data and index address marks during read and write operations.

Data Separator — A digital data separator, consisting of a ring shift register and data window detection logic, provides read data and a recovery clock to the AM detector.

PROCESSOR INTERFACE

The interface to the processor is accomplished through the eight Data Access Lines (DAL) and associated control signals. The DAL are used to transfer Data, Status, and Control words out of, or into the WD1770. The DAL are three state buffers that are enabled as output drivers when Chip Select (\overline{CS}) and $R/\overline{W} = 1$ are active or act as input receivers when \overline{CS} and $R/\overline{W} = 0$ are active.

When transfer of data with the Floppy Disk Controller is required by the host processor, the device address is decoded and \overline{CS} is made low. The address bits A1 and A0, combined with the signal R/\overline{W} , during a Read operation or Write operation are interpreted as selecting the following registers:

A1 - A0	Read ($R/\overline{W} = 1$)	WRITE ($R/\overline{W} = 0$)
0 0	Status Register	Command Register
0 1	Track Register	Track Register
1 0	Sector Register	Sector Register
1 1	Data Register	Data Register

During Direct Memory Access (DMA) types of data transfers between the Data Register of the WD1770 and the processor, the Data Request (DRQ) output is used in Data Transfer control. This signal also appears as status bit 1 during Read and Write operations.

On Disk Read operations, the Data Request is activated (set high) when an assembled serial input byte is transferred in parallel to the Data Register. This bit is cleared when the Data Register is read by the processor. If the Data Register is read after one or more characters are lost, by having new data transferred into the register prior to processor readout, the Lost Data bit is set in the Status Register. The Read operation continues until the end of sector is reached.

On Disk Write operations, the Data Request is activated when the Data Register transfers its contents to the Data Shift Register, and requires a new data byte. It is reset when the Data Register is loaded with new data by the processor. If new data is not loaded at the time the next serial byte is required by the Floppy Disk, a byte of zeroes is written on the diskette and the Lost Data is set in the Status Register.

At the completion of every command, an INTRQ is generated. INTRQ is reset by either reading the status register, or by loading the command register with a new command. In addition, INTRQ is generated if a Force Interrupt command condition is met.

The WD1770 has two modes of operation according to the state \overline{DDEN} (Pin 26). When $\overline{DDEN} = 1$, single density is selected. In either case, the CLK input (Pin 18) is at 8 MHz.

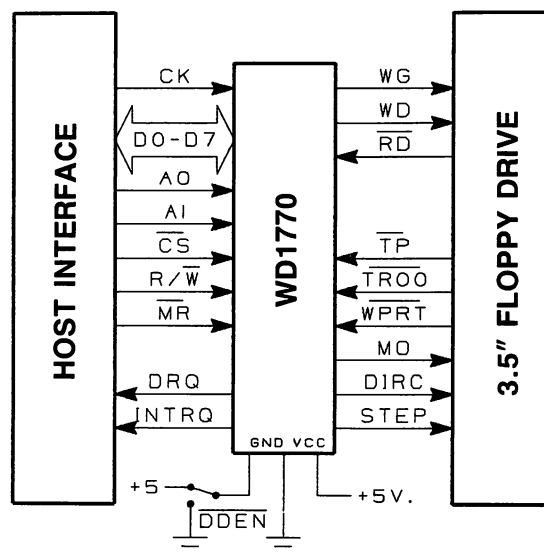

MAJOR PARTS LIST

PCB ASSY 1581	C250471-01
LED ASSY 1581	C250793-01
BEZEL 1581	C252281-01
CASE TOP 1581	C252282-01
CASE BOTTOM 1581	C252283-01
FDD BRACKET, 1581	C252287-01
SHIELD, BOTTOM 1581	C252288-01
INSULATION SHEET 1581	C252290-01
DISKETTE DEMO 1581	C252355-01
MANUAL — USERS	C252358-01
DRIVE ASSY (CHIN F-354E)	C312550-01
MANUAL — SERVICE	C314982-01
POWER SUPPLY 1581	C354027-01

COMPONENTS PARTS LIST

PCB ASSEMBLY #250471-01

U1	IC 6502A 2MHZ CPU	C901435-02
U2	IC EPROM	C312558-02
U2 Sub.	IC 23256 32K X 8 ROM	C312558-01
U3	IC 8K X 8 SRAM	310024-02
U4	IC WD1772 FDC	C310651-02
U4 Sub.	IC WD1770 FDC	C310651-01
U5	IC 8520A-1 2MHZ CIA	C318029-02
U6	IC 74LS139	N/A
U7	IC 74LS00	901521-01
U9	IC 74LS14	901521-30
U10	IC 74LS93	901521-07
U13	IC 74LS241	901521-51
U8, U12	IC 7406	901522-06
U11	IC 7407	901522-30
J1 (Use only with WD1770)	JUMPER WIRE	200018-13
J1 Sub. -13	RES. 47 1/4W 5%	901550-56
RP1	RES. PACK 1K-15 PIN	N/A
RP2	RES. PACK 2.7K-7 PIN	N/A
R1, R3, R9, R10, R11	RES. 47 1/4W 5%	901550-56
R13	RES. 150 1/4W 5%	901550-89
R12	RES. 620 1/4W 5%	901550-40
R2, R14	RES. 1K 1/4W 5%	901550-01
R5	RES. 2.7K 1/4W 5%	901550-23
C1-C14	CAP. 0.1 μ F 16V CER.	252036-02
C18, C22	CAP. 10 μ F 25V ELECTR.	900100-01
C20	CAP. 47 μ F 10V -10 +50 ELECTR.	900100-12
C15	CAP. .01 μ F 50V CER.	251069-20
FB1-6	FERRITE BEAD	903025-04
EMI1-4	EMI FILTER 100PF	251842-02
Y1	CRYSTAL MODULE 16 MHZ	325566-01
CN5	CONN. 3 PIN SIL. .1"	903326-03
CN1 Polarized	CONN. 4 PIN SIL. .1"	325516-04
CN3, CN4	CONN. 6 PIN DIN	252166-01
CN2	CONN. 34 PIN DIL. .1" X .1"	903344-17
CN6	CONN. 5 PIN MINI DIN	250471-01
SW2	SWI. DPDT	252182-01
SW1	SWI. DIP 2 POS.	252144-02
Use on U2 (Item 9)	IC SOCKET 28-PIN	904150-05
CR4	DIODE IN4148	900850-01
CR4 Sub.-01	DIODE IN914	900850-16

C - indicates part is stocked by CBM

ASSEMBLY DRAWING

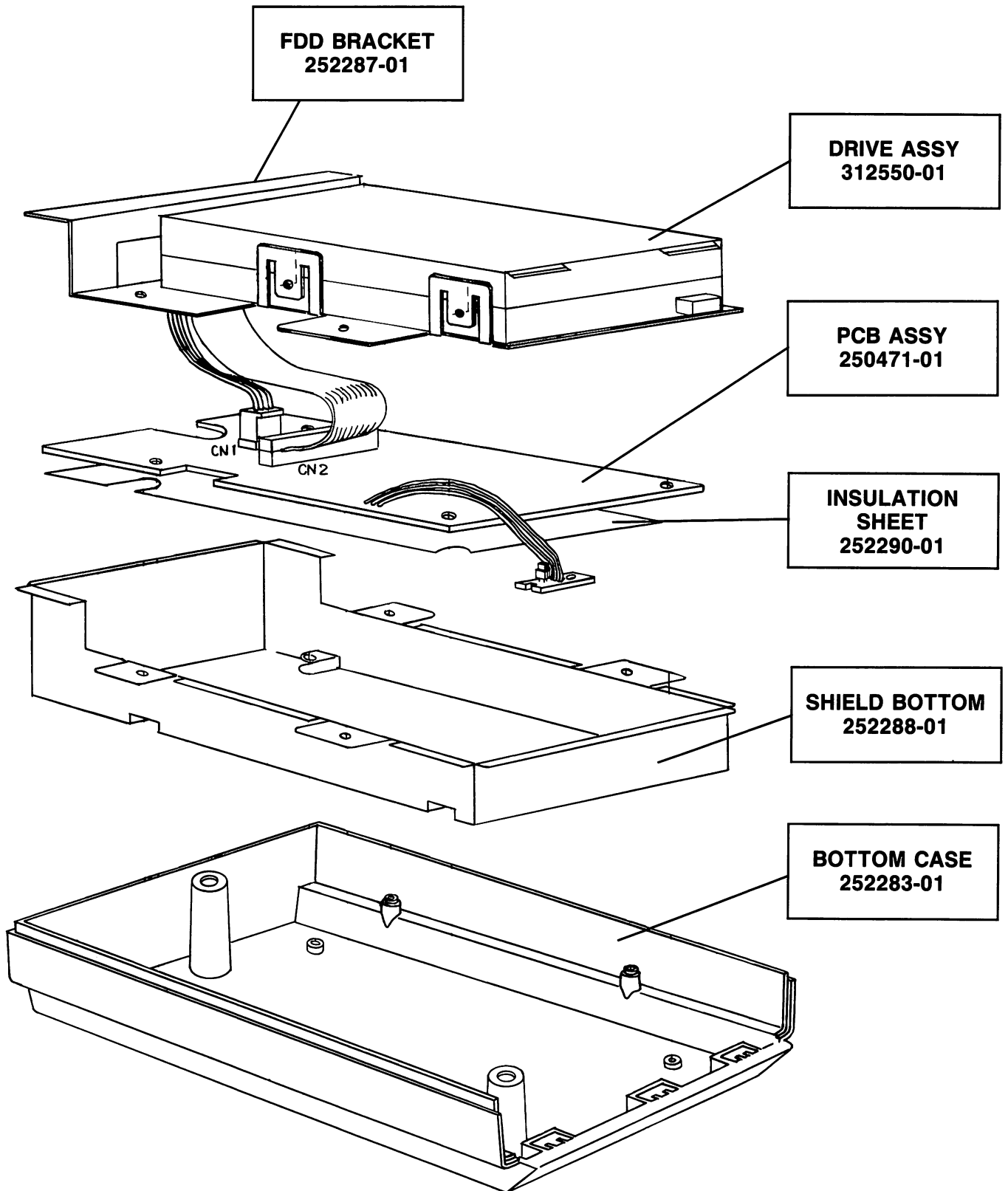

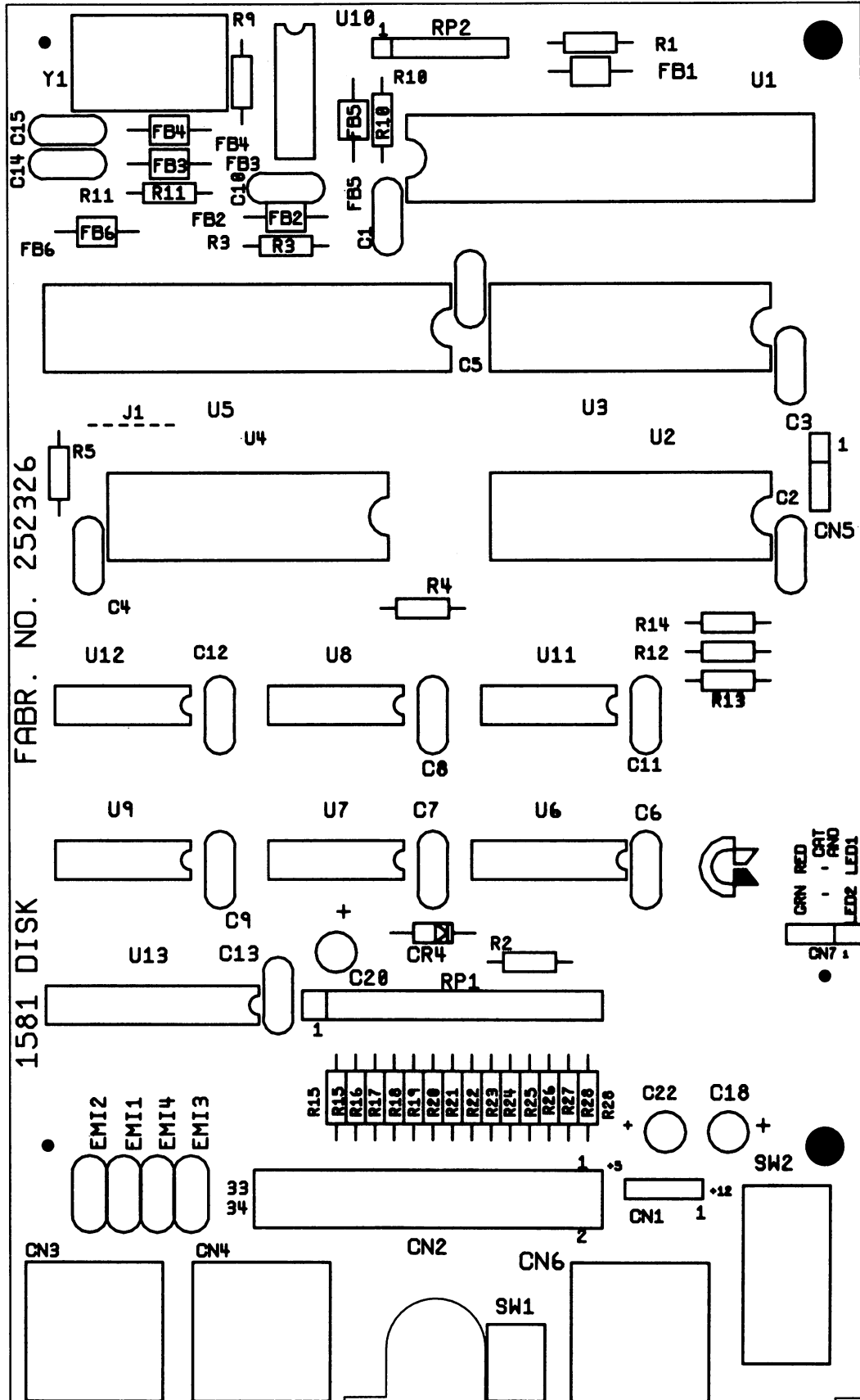

BOARD LAYOUT
PCB ASSEMBLY #250471

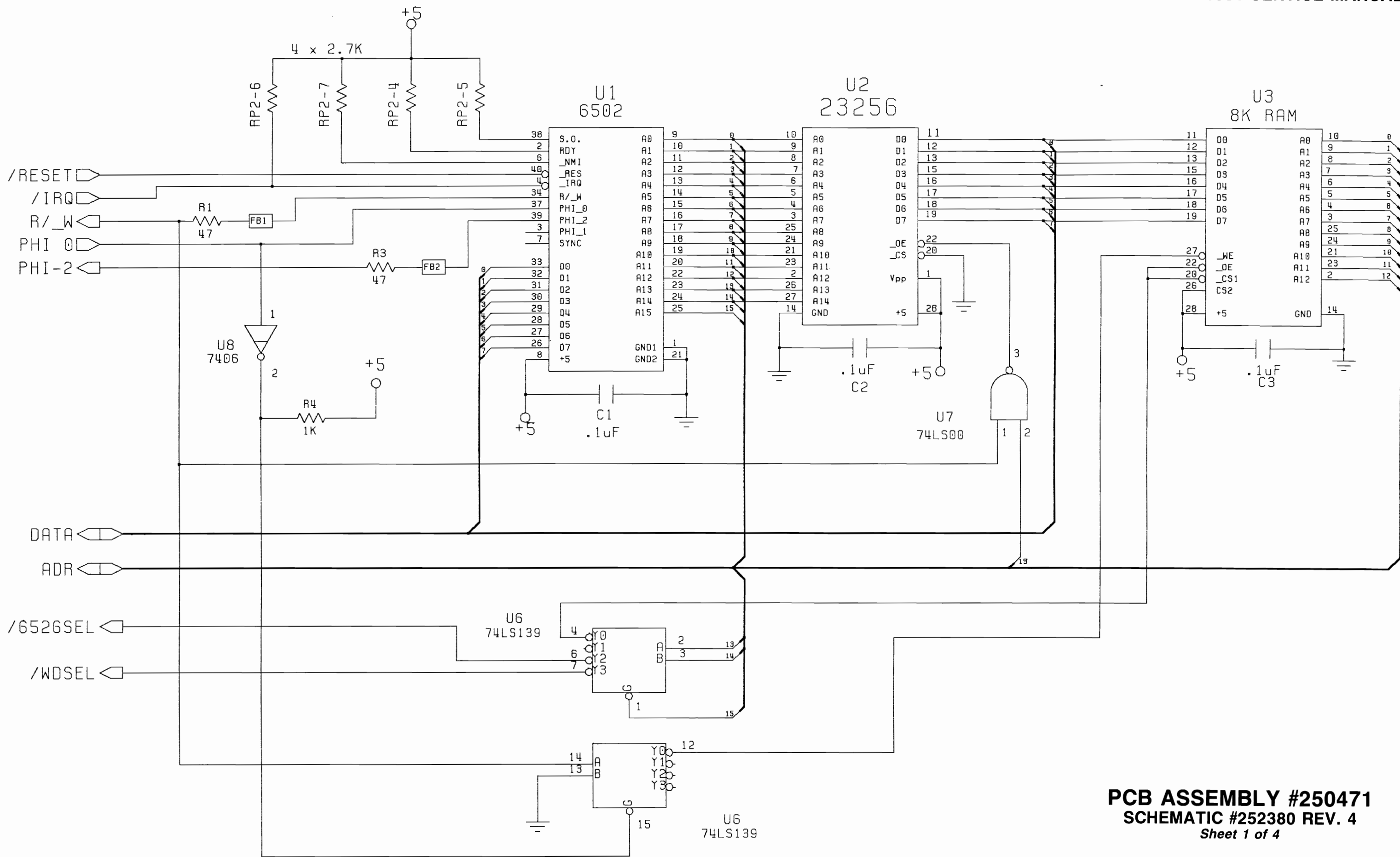

PCB ASSEMBLY #250471
SCHEMATIC #252380 REV. 4
 Sheet 1 of 4

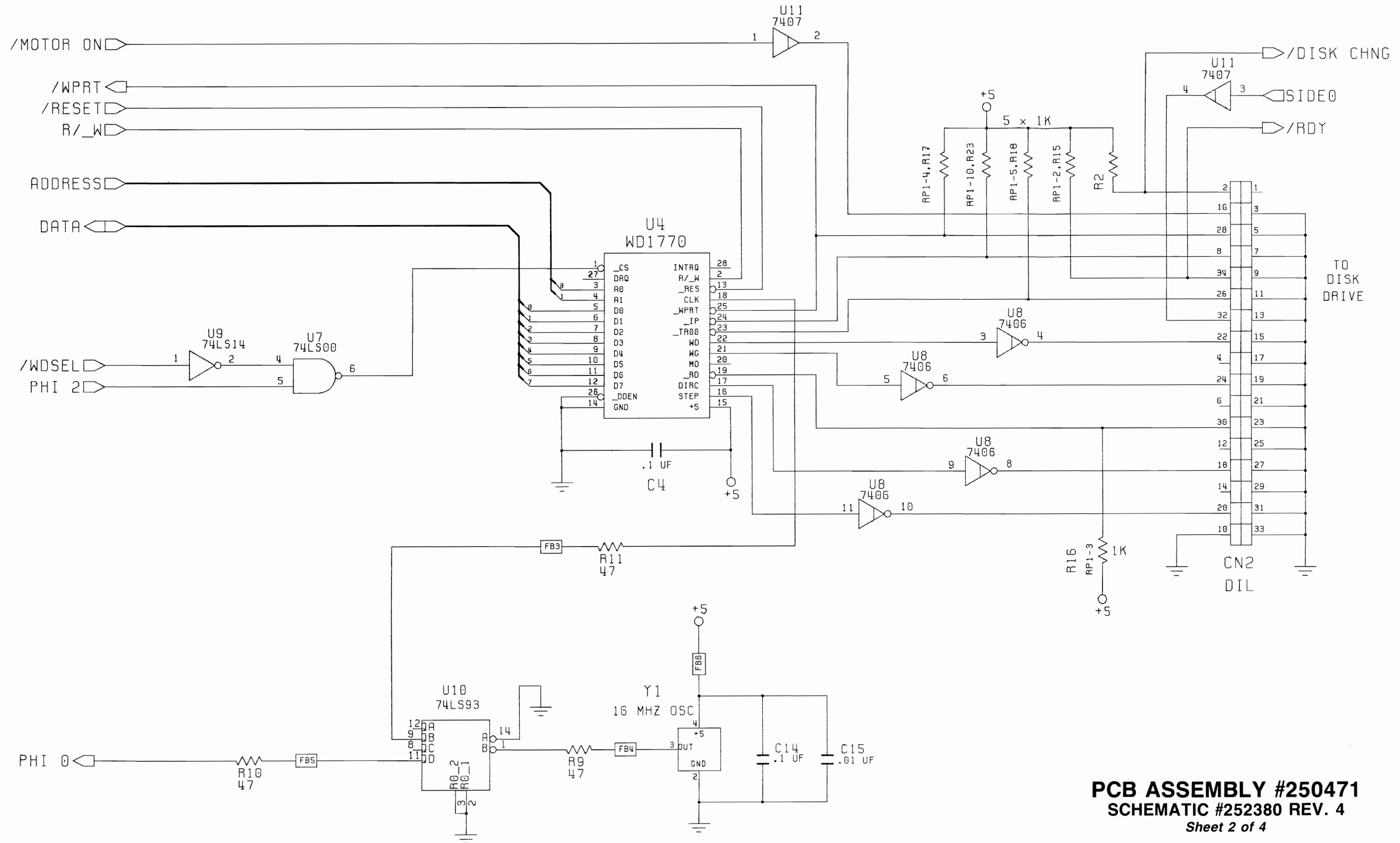

PCB ASSEMBLY #250471
SCHEMATIC #252380 REV. 4
 Sheet 2 of 4

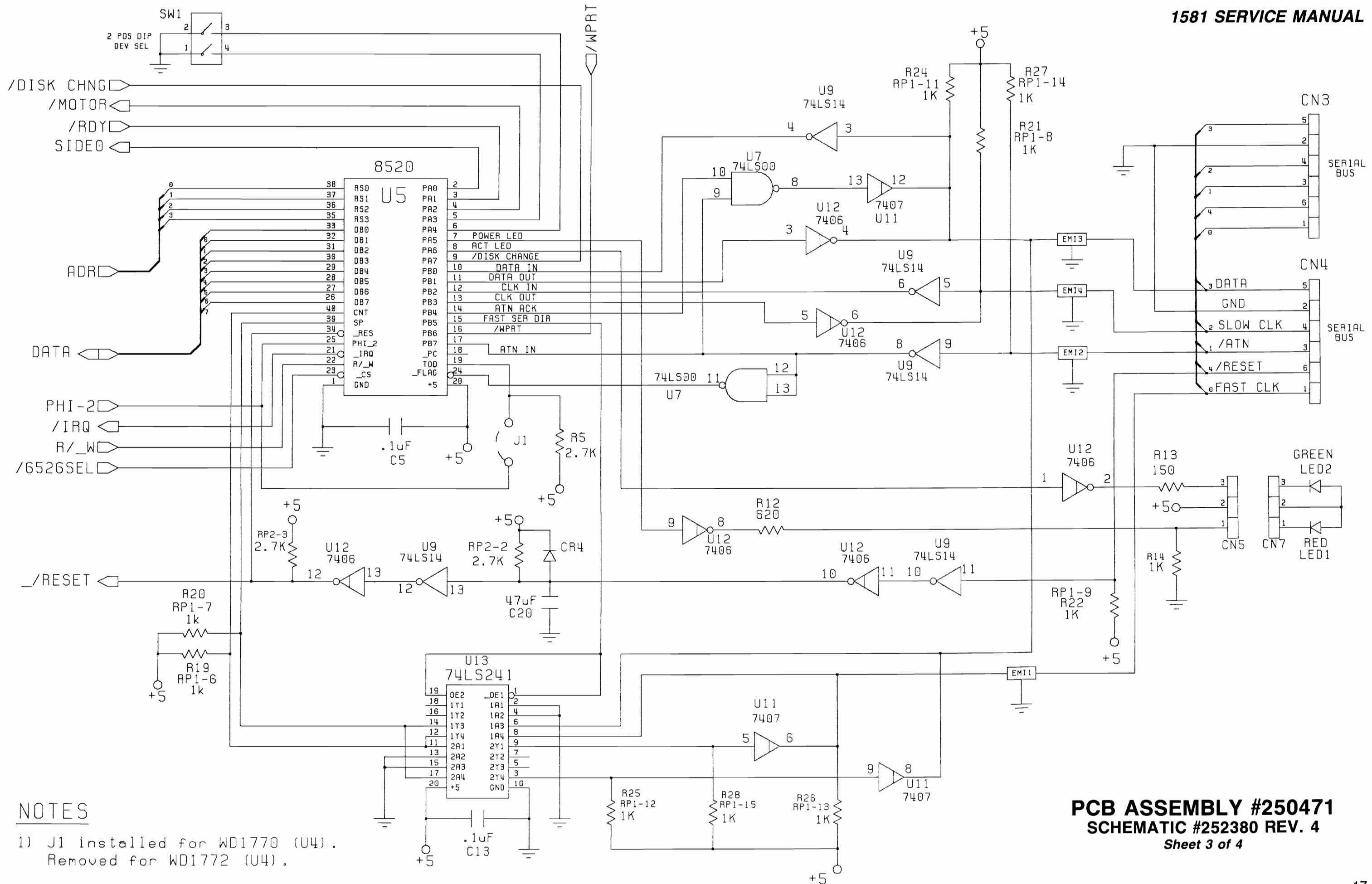

NOTES

- 1) J1 installed for WD1770 (U4).
Removed for WD1772 (U4).

PCB ASSEMBLY #250471
SCHEMATIC #252380 REV. 4
 Sheet 3 of 4

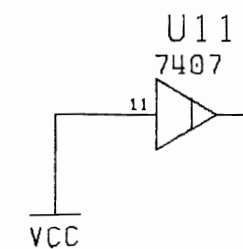
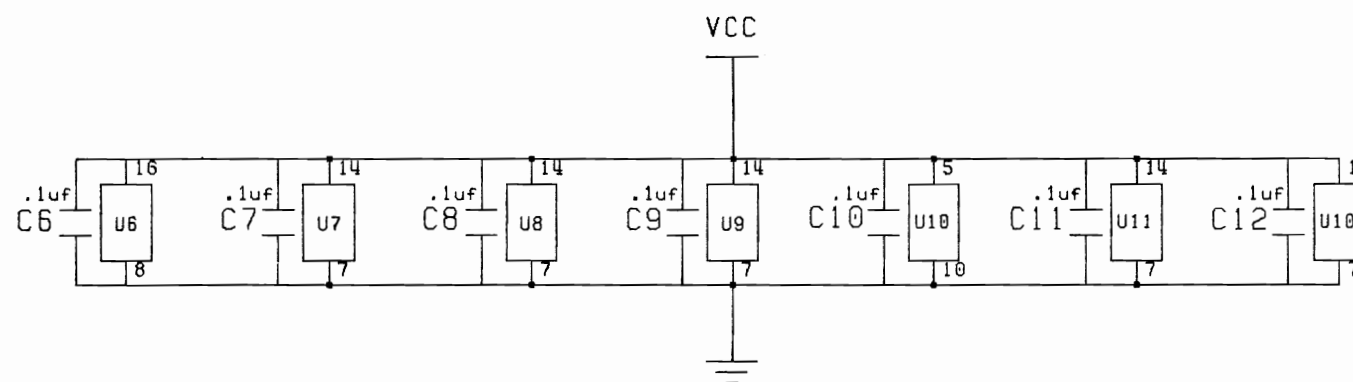
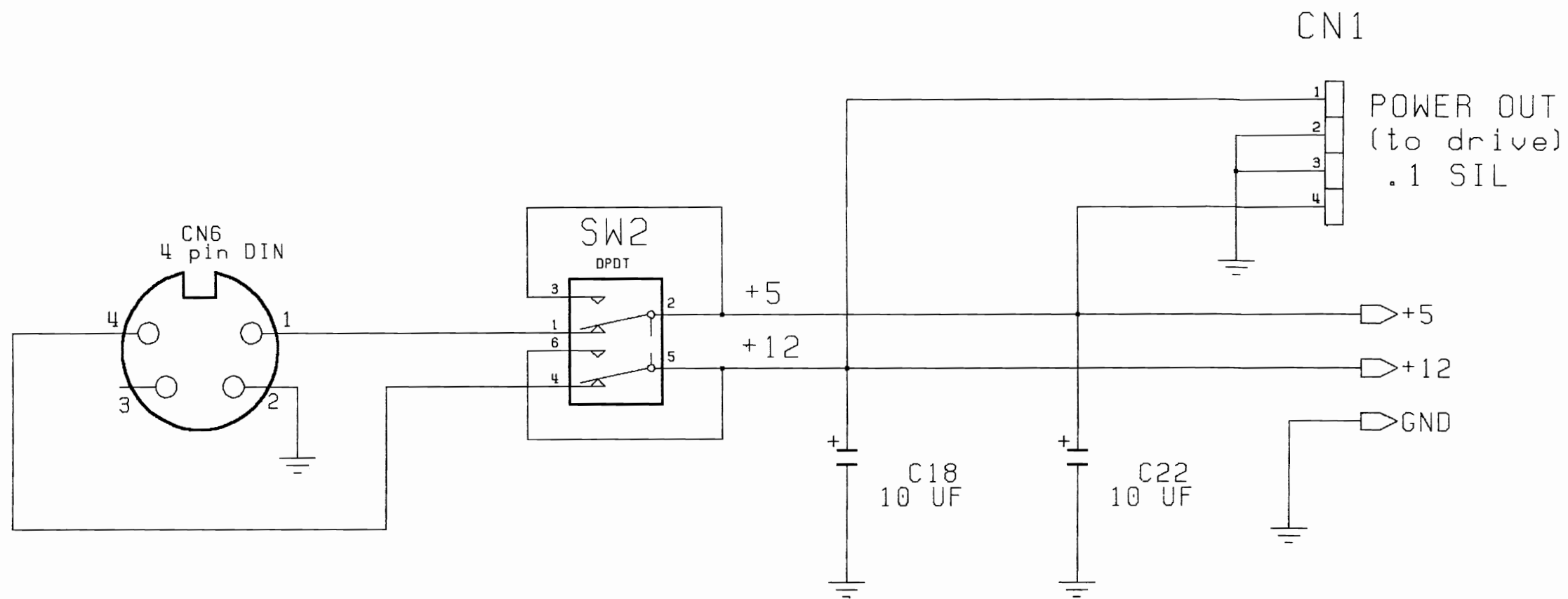

PCB ASSEMBLY #250471
SCHEMATIC #252380 REV. 4
 Sheet 4 of 4



Computer Systems Division
1200 Wilson Drive
West Chester, PA 19380